

HubTamer Elite

No. 6537



Front Wheel Drive Service Tool Set

- Section 1: Parts List and Safety Precautions
HubTamer Operating Instructions – Floating or Trapped Rotors*
- Section 2: Vehicle Specific Operating Instructions - Domestic*
- Section 3: Vehicle Specific Operating Instructions - Import*



Table of Contents

Section 1

Parts List	1
Safety Precautions	2
HubTamer Instructions—Floating (Removable) Rotors . . .	3
HubTamer Instructions—Trapped Rotors	7

Section 2 – Domestic Vehicles

Chrysler / Plymouth / Dodge	11
Ford / Mercury	13
General Motors	17
Saturn	19

Section 3 – Import Vehicles

Acura	21
Audi	23
Eagle	25
Geo	27
Honda	29
Hyundai	31
Infiniti	33
Lexus	35
Mazda	37
Mitsubishi	39
Nissan	41
Subaru	43
Toyota	45
Volkswagen	47
Warranty Information	Inside Back Cover



Parts List

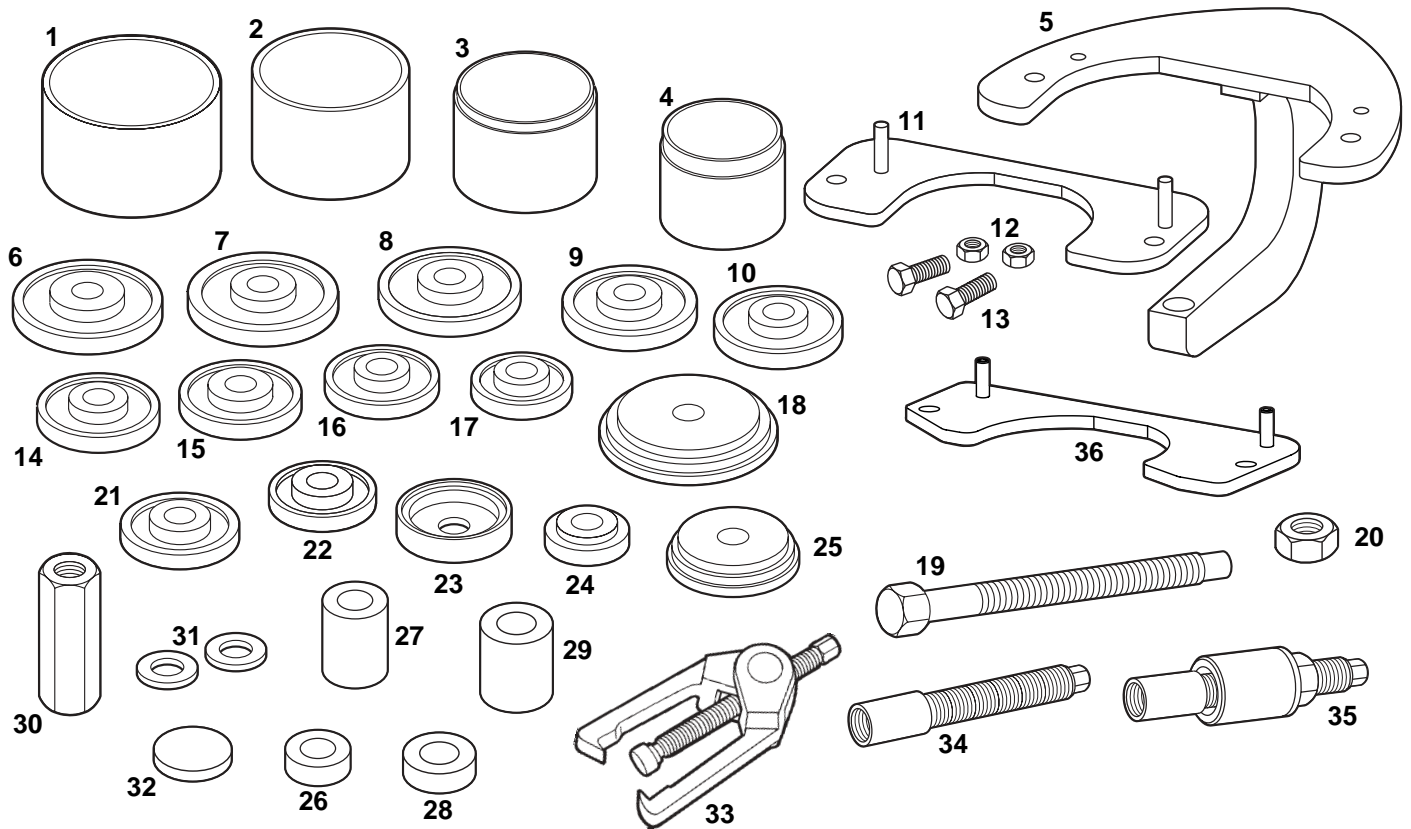

Item No.	Part No.	No. Req'd	Description
1	314300	1	Tube
2	314299	1	Tube
3	311882	1	Tube
4	311883	1	Tube
5	503004	1	FWD Hub Puller
6	314308	1	Bearing Installer
7	314311	1	Bearing Installer
8	314310	1	Bearing Installer
9	314309	1	Bearing Installer
10	314307	1	Bearing Installer
11	503902	1	Small Adapter Assembly
12	10204	2	Hex Nut (3/8-16)
13	10048	2	Hex Hd. Cap Screw (3/8-16 x 7/8)
14	314305	1	Bearing Installer
15	314306	1	Bearing Installer
16	314304	1	Bearing Installer
17	314302	1	Bearing Installer
18	314301	1	Adapter (2-step)
19	503052	1	Forcing Screw
20	22301	1	Hex Nut (3/4-16)
21	311885	1	Bearing Installer
22	311886	1	Bearing Installer
23	311888	1	Wheel Hub Installer
24	311887	1	Bearing Remover
25	311884	1	Adapter (2-step)
26	503633	1	Sleeve
27	502622	1	Sleeve
28	503634	1	Sleeve
29	502623	1	Sleeve
30	311881	1	Forcing Screw Nut
31	219646	2	Washer
32	503896	1	Race Puller Adapter
33	7503	1	Outer Tie Rod Remover
34	314288	1	Forcing Screw
35	7135	1	Front Hub Installer
36	6536	1	Ford Adapter
		1	Plastic Storage Case (not shown)

Refer to any operating instructions included with the product for detailed information about operation, testing, disassembly, reassembly, and preventive maintenance.

Items found in this parts list have been carefully tested and selected by OTC. **Therefore: Use genuine OTC replacement parts!**

Additional questions can be directed to our Technical Services Dept. at 1-800-533-6127.

Refer to the back of this sheet for adapter dimensions.

Adapter Dimensions and Safety Precautions

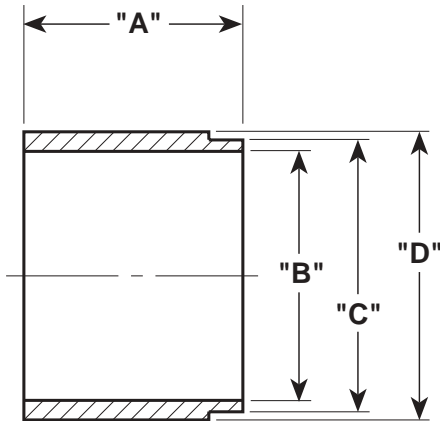
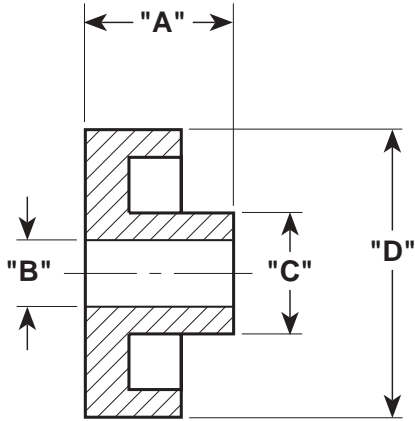

Part No.	Dim. "A"	Dim. "B"	Dim. "C"	Dim. "D"
311885	.750	.781	1.540	2.960
311886	.750	.781	1.500	2.625
311887	.680	.781	1.500	2.188
314302	.750	.781	1.310	2.500
314304	.750	.781	1.360	2.780
314305	.750	.781	1.480	2.820
314306	.750	.781	1.640	2.820
314307	.750	.781	1.480	2.900
314308	.750	.781	1.870	3.480
314309	.750	.781	1.620	3.055
314310	.750	.781	1.620	3.210
314311	.750	.781	1.670	3.290
311882	2.500	3.060	3.190	3.250
311883	2.500	2.750	2.955	3.000
314299	2.500	3.250	N/A	3.625
314300	2.500	3.750	N/A	4.000

Safety Precautions



Warning: To prevent personal injury,

- Read, understand, and follow all safety precautions and instructions included with this tool. If the operator cannot read English, operating instructions and safety precautions must be read and discussed in the operator's native language.
- Si el operador no puede leer inglés, las instrucciones de operación y las precauciones de seguridad deberán leerse y comentarse en el idioma nativo del operador.
- Si l'utilisateur ne peut lire l'anglais, les instructions et les consignes de sécurité doivent lui être expliquées dans sa langue maternelle.
- Wear eye protection that meets ANSI Z87.1 and OSHA standards.
- Cover the work with a protective blanket (see OTC catalog) or canvas, because applying force to a part can cause breakage.

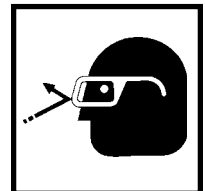
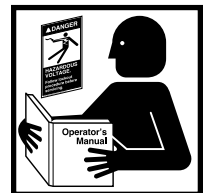

HubTamer Instructions – Floating (Removable) Rotors

The following procedure for using the HubTamer does not apply to vehicles that have complete hub assemblies.
For example: 1996–current Ford Taurus, or all GM vehicles.

These tools are designed to remove and install front wheel drive front wheel bearings. It is not necessary to remove the knuckle assembly from the vehicle, and, as a result, front wheel alignment is not altered.

Vehicle Setup

1. Raise the vehicle until all weight is off the front wheels, and they hang freely.
2. Remove the following components:
 - front tires
 - axle nut
 - outer tie rod nut and tie rod
 - disc brake caliper - use a wire (or OTC No. 7661 caliper hanger set) to hold caliper out of the way and prevent damage to brake hose
 - brake rotor
 - loosen the lower ball joint from the steering knuckle assembly

3. Lubricate the forcing screw in the tool set.

Using the HubTamer *(item numbers refer to the parts list on page 1)*

1. Prepare the vehicle by removing the components listed above in *Vehicle Setup*.
2. Separate the lower ball joint from the spindle assembly.
3. Mount a hub puller (OTC No. 7208A; not included) on the vehicle hub assembly as shown in Figure 1. Apply force to the forcing screw until the axle can be removed as shown in Figure 2. Use wire to tie the axle out of the way; do not let it hang free.

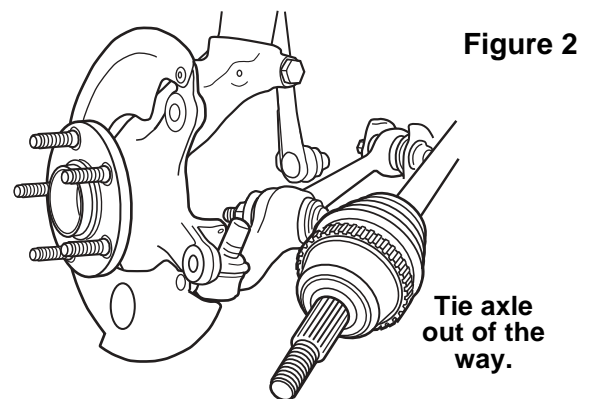
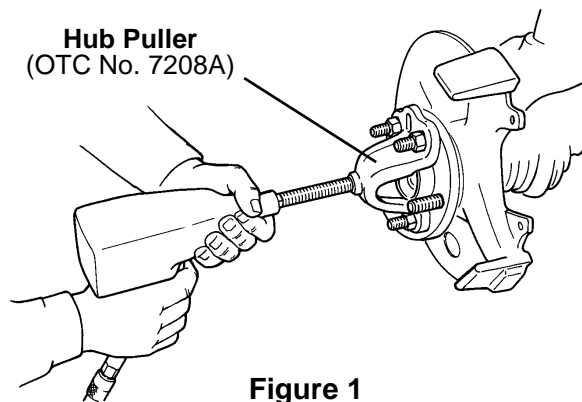

4. Determine which of the four sleeves (Items 26-29) fits the application. The sleeve should push against the hub, but slide through the bearing.
5. Assemble the HubTamer as shown in Figure 3.

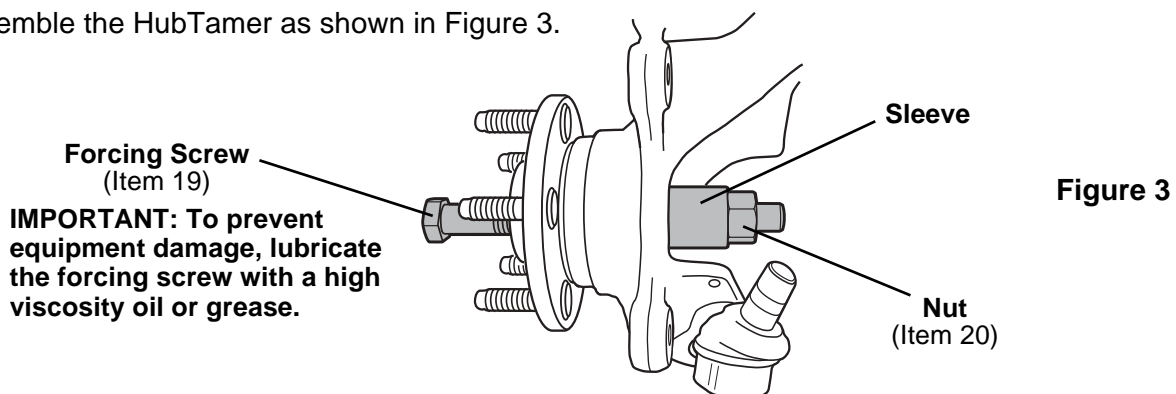

HubTamer Instructions – Floating (Removable) Rotors

6. Slide the HubTamer yoke (No. 5) over the hub in the area where the brake caliper was removed. Verify the yoke will be pushing on the knuckle casting, NOT on the dust shield.

A. If the yoke is too big to get a good grip on the knuckle casting, assemble the No. 503902 small adapter (No. 11) to the yoke as shown in Figure 4. Insert the pins on the adapter into the holes in the yoke. Whenever clearance allows, assemble the bolts as shown in Figure 4—this adds strength to the HubTamer.

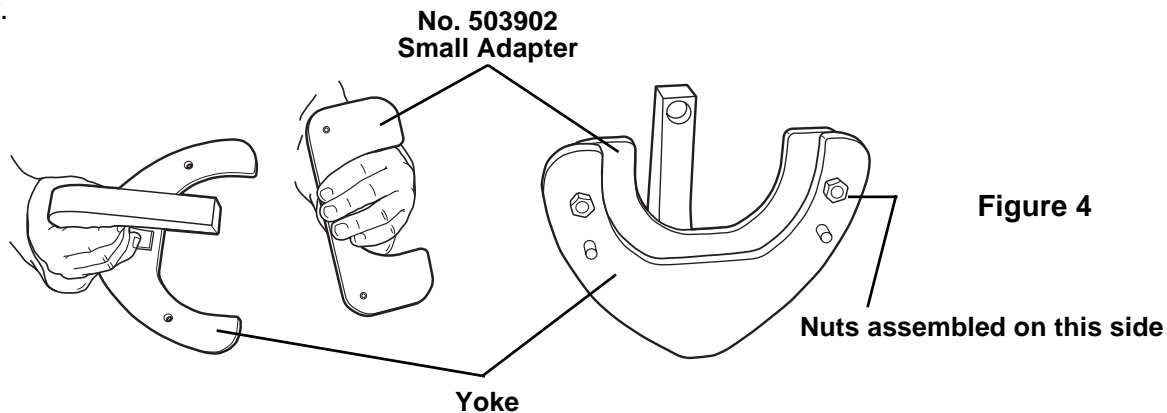

B. 1995–2001 Contour / Mystique and 1986–1995 Taurus / Sable Applications: Assemble No. 6536 Ford Adapter to the HubTamer.

1) Assemble the HubTamer as shown in Figure 3 using sleeve No. 502623 (item 29).

2) Insert the pins on the No. 6536 Ford Adapter (item 36) into the holes in the HubTamer yoke. Assemble the bolts as shown in Figure 5—this adds strength to the HubTamer. **Important: If the bolts are not assembled to the adapter and yoke, the adapter may bend during usage.**

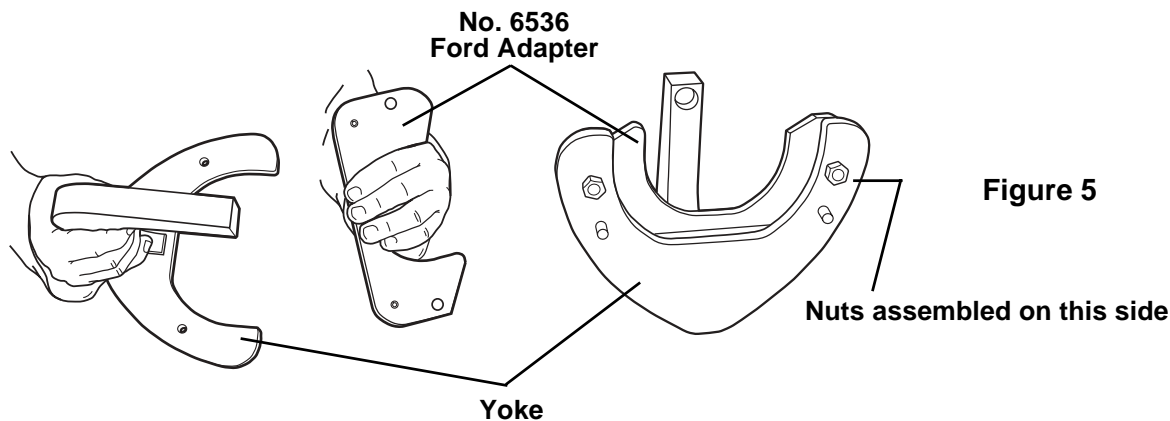

7. Hand tighten the nut on the end of the forcing screw. Check the alignment of the setup—the yoke assembly must be at a 90° angle to the knuckle. See Figure 6. Verify the HubTamer will be pushing on the knuckle casting, NOT the dust shield.

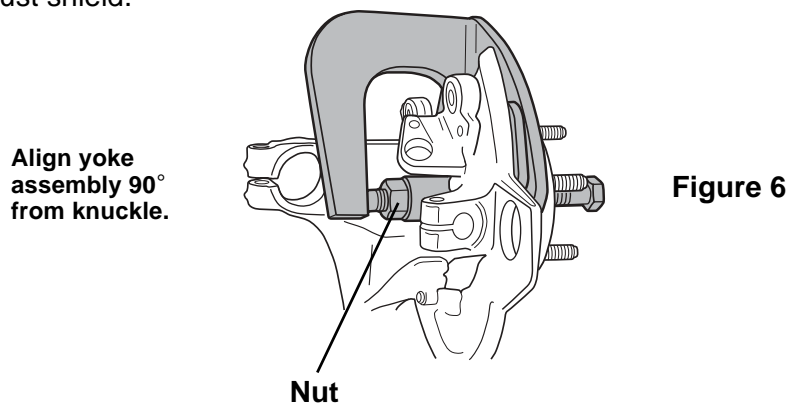

HubTamer Instructions – Floating (Removable) Rotors

8. Using a 1-1/8" wrench on the nut, and a 1-1/16" socket with impact wrench on the head of the forcing screw, tighten the forcing screw into the nut to draw the hub out of the knuckle. See Figure 7.

Tip: If the hub does not easily break loose from the knuckle, stop using the impact wrench when it starts to "labor" (when there is a change in sound). Strike the top of the HubTamer with a hammer. Once the hub breaks loose, continue using the impact wrench.

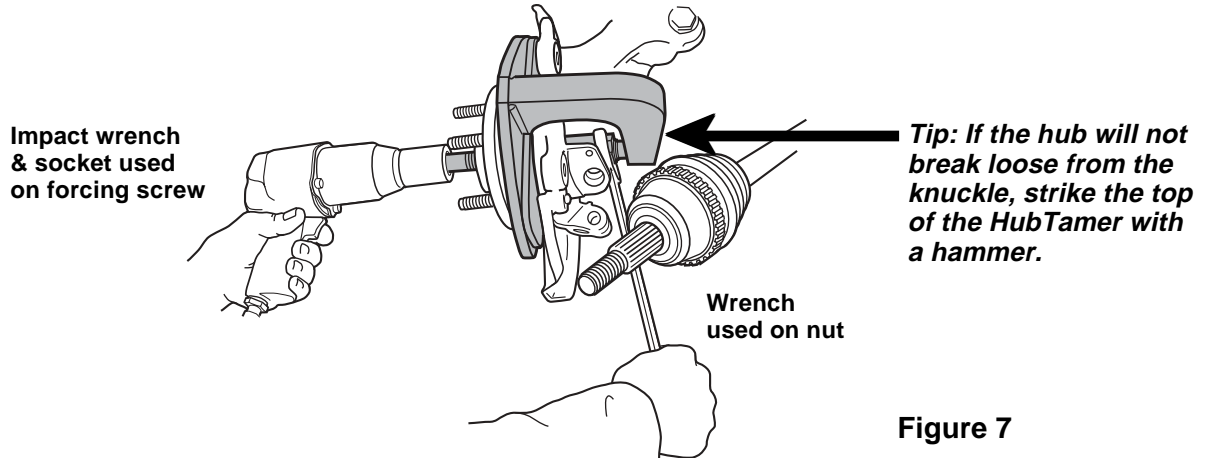

9. If the race from the old bearing is still stuck in the hub, use No. 7503 (No. 33) with a spacer (No. 32), as shown in Figure 8, to remove the race.

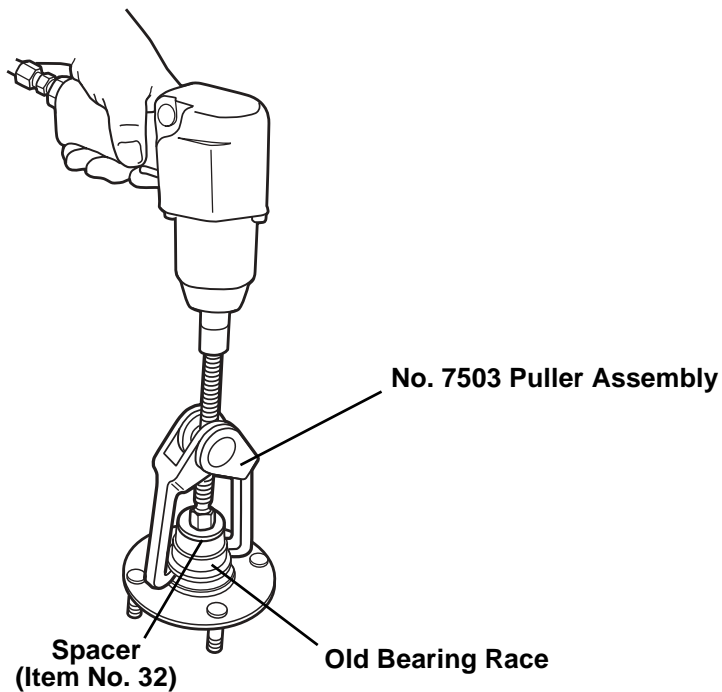

Figure 8

10. Remove any seal or shroud that will restrict the bearing from being removed.

HubTamer Instructions – Floating (Removable) Rotors

11. Remove the snap ring from the appropriate side of the spindle assembly. See Figure 9. **Note: On Chrysler vehicles, with the exception of Neon, remove the three bolts from the bearing retainer as shown in Fig. 10. On Neon vehicles, remove the snap ring from the inboard (CV joint) side of the knuckle.**

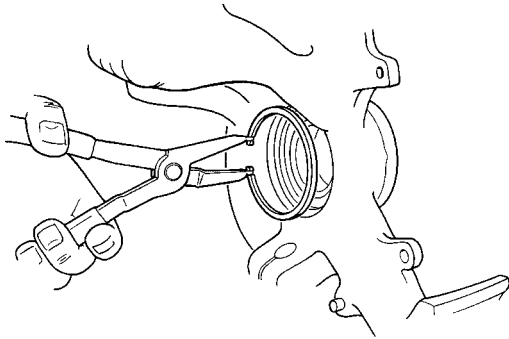

Figure 9

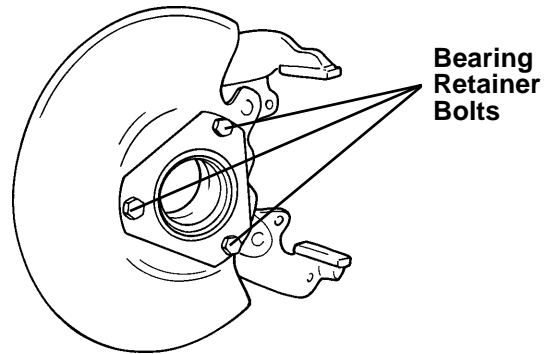

Figure 10
Chrysler Vehicles (except Neon)

12. Proceed to the following vehicle section that applies to your specific application.

HubTamer Instructions – Trapped Rotors

The following procedure for using the HubTamer does not apply to vehicles that have complete hub assemblies.
For example: 1996–current Ford Taurus, or all GM vehicles.

These tools are designed to remove and install front wheel drive front wheel bearings. It is not necessary to remove the knuckle assembly from the vehicle, and, as a result, front wheel alignment is not altered.

Vehicle Setup

1. Raise the vehicle until all weight is off the front wheels, and they hang free.
2. Remove the following components:
 - front tires
 - axle nut
 - outer tie rod nut and tie rod
 - disc brake caliper - use a wire (or OTC No. 7661 caliper hanger set) to hold caliper out of the way and prevent damage to brake hose
 - loosen the lower ball joint from the steering knuckle assembly
3. **Lubricate the forcing screw in the tool set.**

Using the HubTamer *(item numbers refer to the parts list on page 1)*

1. Prepare the vehicle by removing the components listed above in *Vehicle Setup*.
2. Separate the lower ball joint from the spindle assembly.
3. Mount a hub puller (OTC No. 7208A; not included) on the vehicle hub assembly as shown in Figure 1. Apply force to the forcing screw until the axle can be removed as shown in Figure 2. Use wire to tie the axle out of the way; do not let it hang free.

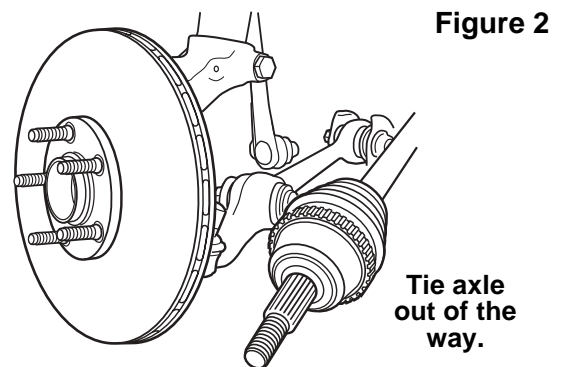
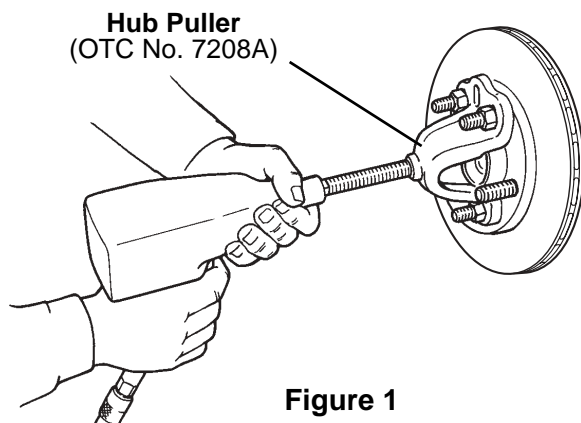

4. Determine which of the four sleeves (Items 26-29) fits the application. The sleeve should push against the hub, but slide through the bearing.
5. Assemble the HubTamer as shown in Figure 3.

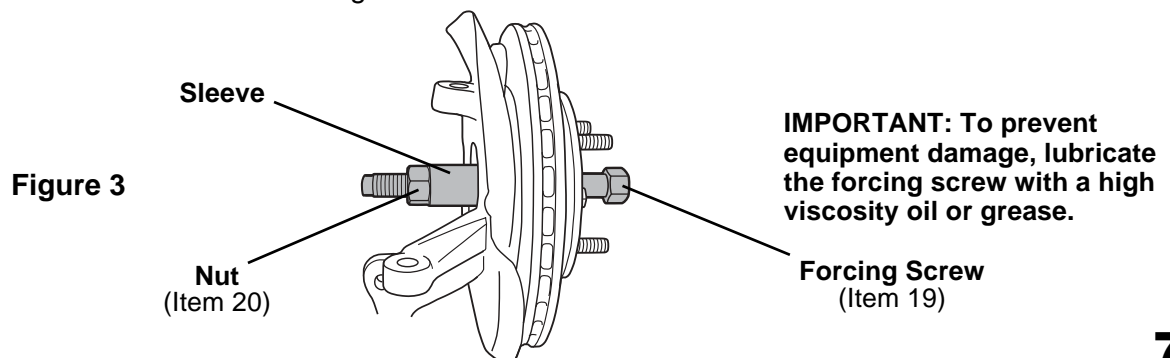

HubTamer Instructions – Trapped Rotors

- Slide the HubTamer yoke (No. 5) over the hub in the area where the brake caliper was removed.
- Verify the yoke will be pushing on the knuckle casting, NOT on the dust shield. If the yoke is too big to get a good grip on the knuckle casting, assemble the small adapter (No. 11) to the yoke as shown in Figure 4. Insert the pins on the adapter into the holes in the yoke. Whenever clearance allows, assemble the bolts as shown in Figure 4—this adds strength to the HubTamer.

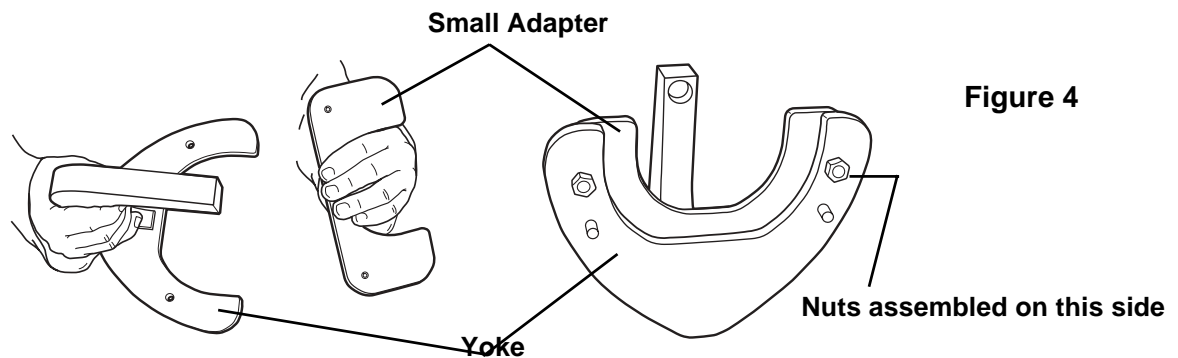

- Hand tighten the nut on the end of the forcing screw. Check the alignment of the setup—the yoke assembly must be at a 90° angle to the knuckle. See Figure 5. Verify the HubTamer will be pushing on the knuckle casting, NOT the dust shield.

Align yoke assembly 90° from knuckle.

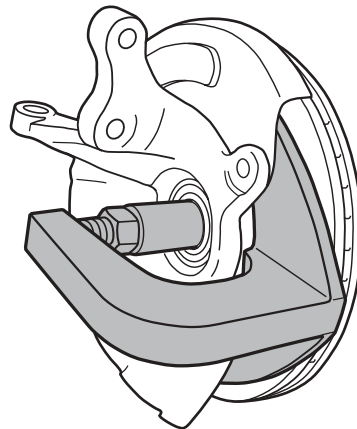

Figure 5

- Using a 1-1/8" wrench on the nut, and a 1-1/16" socket with impact wrench on the head of the forcing screw, tighten the forcing screw into the nut to draw the hub out of the knuckle. See Figure 6.

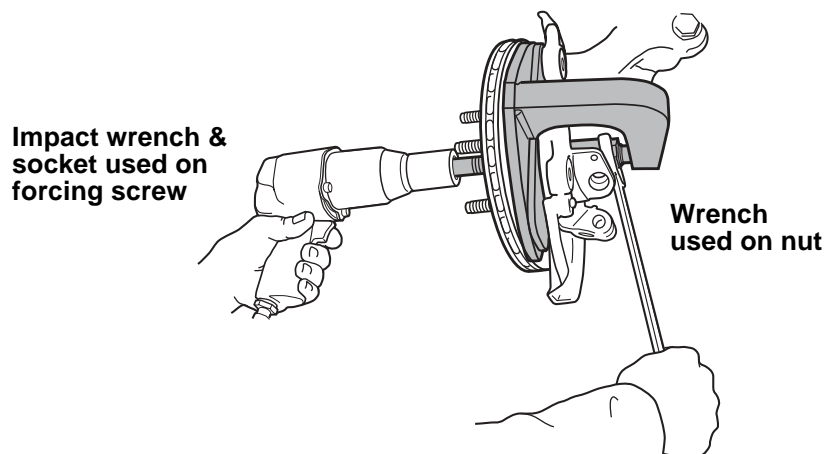

Figure 6

HubTamer Instructions – Trapped Rotors

Tip: If the hub will not break loose from the knuckle, verify the tool setup is tight and aligned straight. Strike the top of the HubTamer with a hammer as shown in Figure 7. Once the hub breaks loose, use the 1-1/8" wrench and impact wrench with socket to tighten the forcing screw into the nut to draw the hub out of the knuckle.

If the hub will not break loose from the knuckle, strike the top of the HubTamer with a hammer.

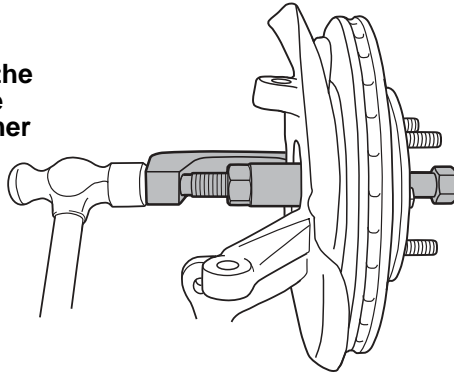

Figure 7

10. Remove the four fasteners holding the hub to the rotor, and separate the rotor from the hub. See Fig. 8.

Remove the fasteners holding the hub to the rotor.

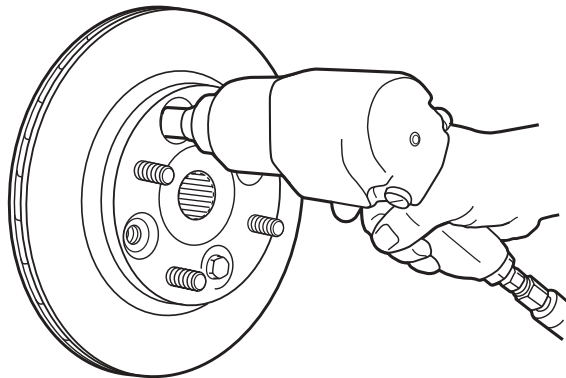

Figure 8

11. If the race from the old bearing is still stuck in the hub, use No. 7503 (No. 33) with a spacer (No. 32), as shown in Figure 9, to remove the race.

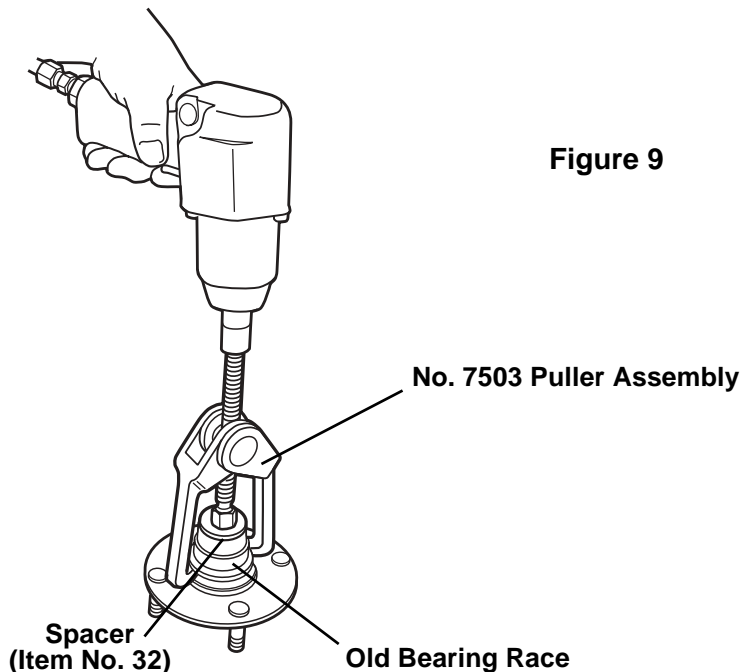

Figure 9

HubTamer Instructions – Trapped Rotors

12. Remove any seal or shroud that will restrict the bearing from being removed.
13. Remove the snap ring from the appropriate side of the spindle assembly. See Figure 10. **Note: On Honda vehicles, remove the four fasteners holding the bearing to the knuckle assembly. See Figure 11.**

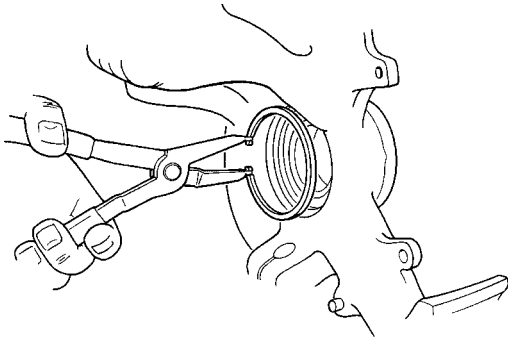
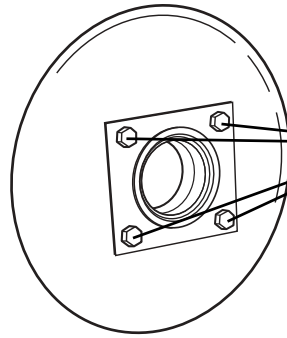

Figure 10



On Honda vehicles, remove the four fasteners holding the bearing to the knuckle assembly. Use a hammer to tap the bearing assembly out of the knuckle assembly.

Figure 11

14. Proceed to the following vehicle section that applies to your specific application.

HubTamer Elite

No. 6537



Front Wheel Drive Service Tool Set

Section 2: Vehicle Specific Operating Instructions - Domestic



Table of Contents

Section 1

Parts List	1
Safety Precautions	2
HubTamer Instructions—Floating (Removable) Rotors . . .	3
HubTamer Instructions—Trapped Rotors	7

Section 2 – Domestic Vehicles

Chrysler / Plymouth / Dodge	11
Ford / Mercury	13
General Motors	17
Saturn	19

Section 3 – Import Vehicles

Acura	21
Audi	23
Eagle	25
Geo	27
Honda	29
Hyundai	31
Infiniti	33
Lexus	35
Mazda	37
Mitsubishi	39
Nissan	41
Subaru	43
Toyota	45
Volkswagen	47
Warranty Information	Inside Back Cover

Chrysler / Plymouth / Dodge

R = Remove I = Install	314299	314300	314301	314302	314304	314305	314306	314307	314308	314309	314310	314311	311882	311883	311884	311885	311886	311887	311888	
Chrysler 1982-88 All 1989-90 LeBaron 1989-90 Town & Country													R	I	RI	I			RI	I
Plymouth 1980-83 All 1983 Voyager 1984-90 Acclaim, Caravelle, Reliant, Sundance 1984-90 Horizon Turismo 1984-90 Voyager													R	I	RI	I			RI	I
Dodge 1980-83 All 1982-84 Rampage 1984-87 Charger 1984-89 Dynasty, Shelby, Charger 600 1984-89 Omni GLH 1984-90 Aries, Lancer, Shadow 1984-90 Caravan 1984-90 Daytona 1984-90 Omni 1989-90 Spirit													R	I	RI	I			RI	I
1993-94 Colt 1995-00 Neon 2001-04 Neon 2001-04 PT Cruiser	R		RI																RI	I

1. Determine if the vehicle has a trapped rotor or a floating rotor. Refer to the corresponding *HubTamer Instructions* section of this manual to remove the hub.
2. Assemble the tool components as shown in Figure 1, and press out the worn bearing.

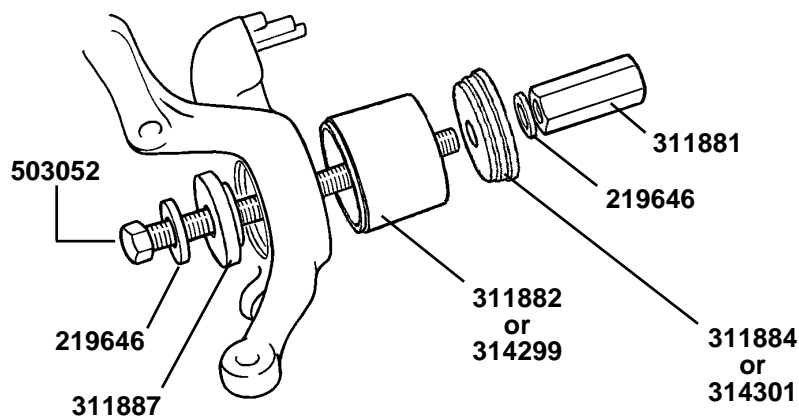
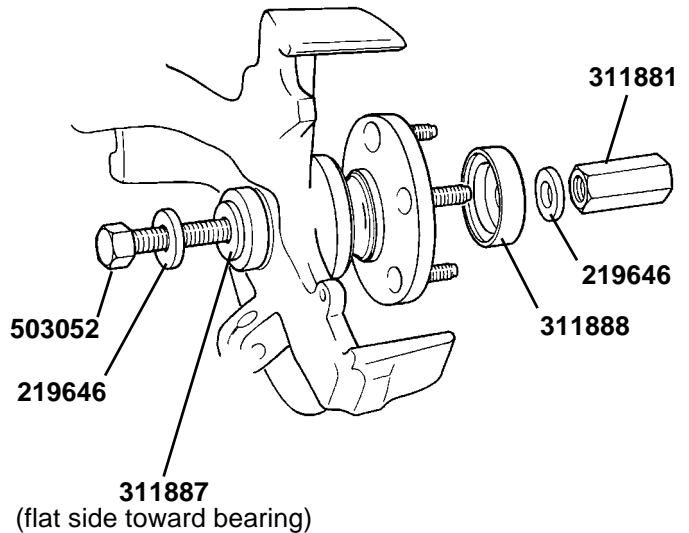
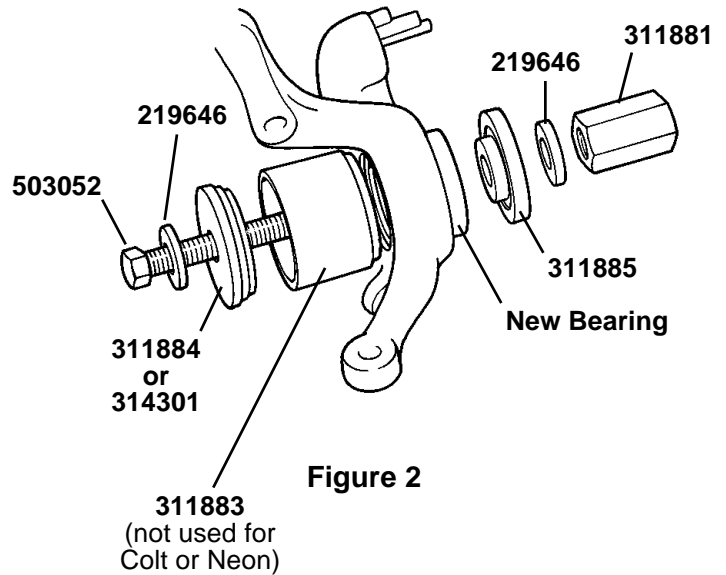

Figure 1

3. Lightly lubricate the new bearing, and position it for installation with the tool components assembled as shown in Figure 2. Press the bearing into the spindle assembly until it bottoms.
4. Fasten the bearing retainer in place using the bearing retainer bolts. (On Neon vehicles, install the snap ring in the knuckle.)
5. Assemble tool components as shown in Figure 3. Lightly oil the hub assembly, and install the hub.

Important: The bearing installer must be assembled with the flat side toward the bearing and the small diameter pilot on the side away from the bearing.

6. Assemble the remaining vehicle components that were removed for bearing replacement:
 - lower ball joint to steering knuckle assembly
 - brake rotor
 - disc brake caliper
 - outer tie rod nut and tie rod
 - axle nut
 - front tires



Ford / Mercury

R = Remove I = Install	314299	314300	314301	314302	314304	314305	314306	314307	314308	314309	314310	314311	311882	311883	311884	311885	311886	311887	311888
1983-90 Escort / Lynx, EXP / LN7 1983-94 Tempo / Topaz														R	RI		I	R	I
1986-95 Taurus / Sable * 1995-98 Windstar													R		RI	I		R	I
1991-99 Escort / Tracer						RI							R		RI				I
1993-97 Probe	R		RI							I								R	I
1993-99 Villager	R		R							I					I			RI	I
1995-01 Contour/Mystique *								I					R		RI			R	I
2000-04 Focus	R		RI			I												RI	I
1994-97 Aspire	Tapered roller bearing does not require adapters for bearing removal - use HubTamer.																	I	I

* Refer to *HubTamer Instructions – Floating (Removable) Rotors* for instructions regarding hub removal.

- Determine if the vehicle has a trapped rotor or a floating rotor. Refer to the corresponding *HubTamer Instructions* section of this manual to remove the hub.
- Assemble the tool components as shown. **Important: The internal chamfer on the end of the tube (No. 311882 or 311883) faces the wheel knuckle. The chamfer aligns the tube with the wheel knuckle so it doesn't slip off the surface and cock.**
 - The **1986-95 Taurus/Sable** application uses the larger tube (No. 311882) with the 2-step adapter (No. 311884). See Figure 1.
 - The **1983-94 Tempo/Topaz and 1983-1990 Escort/Lynx** applications use the smaller tube (No. 311883) with the 2-step adapter. See Fig. 1.
 - The **1995-2001 Contour/Mystique** application uses bearing installer No. 311887. See Figure 2.
 - The **1991-99 Escort/Tracer** application uses bearing installer No. 314305. See Figure 2.
 - The **1993-99 Villager** application uses bearing installer No. 314299 and step adapter No. 314301. See Figure 2.

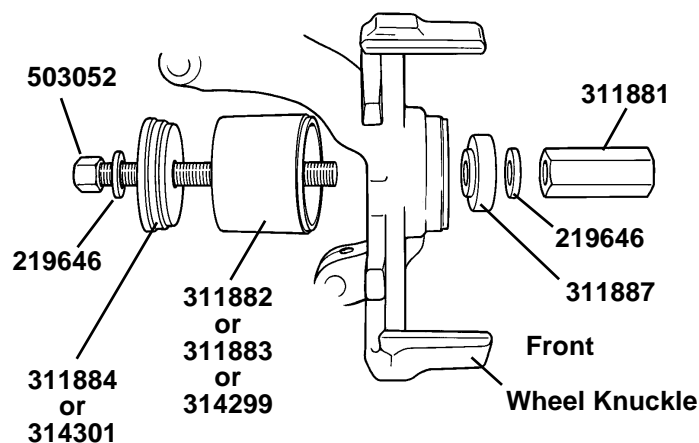

Figure 1

1986-95 Taurus / Sable
1995-98 Windstar
1983-94 Tempo / Topaz
1983-90 Escort / Lynx
1993-97 Probe
2000-04 Focus

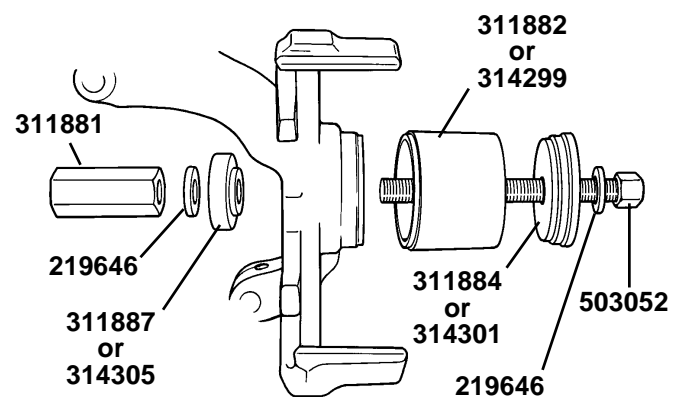

Figure 2

1995-2001 Contour / Mystique
1991-99 Escort / Tracer
1993-99 Villager

Ford / Mercury

3. Use a wrench to hold the forcing screw (Figure 3) or forcing screw nut (Figure 4), and press out the worn bearing.

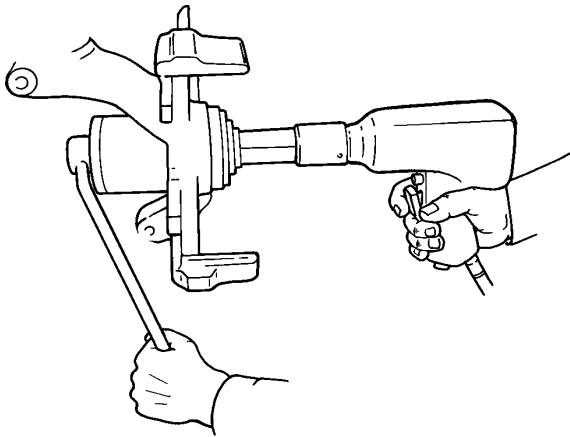

Figure 3

1986-95 Taurus / Sable
1995-98 Windstar
1983-94 Tempo / Topaz
1983-90 Escort / Lynx
1993-97 Probe
2000-04 Focus

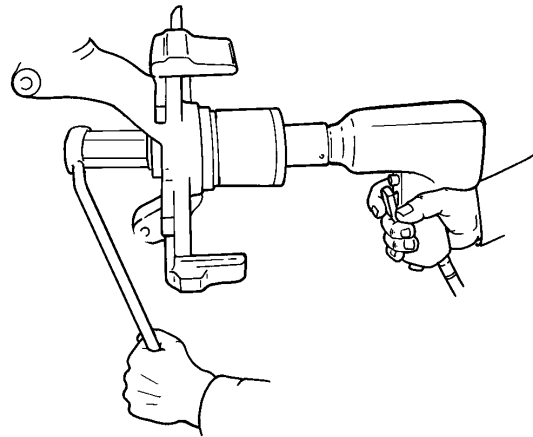

Figure 4

1995-2001 Contour / Mystique
1991-99 Escort / Tracer
1993-99 Villager

4. Lightly lubricate the new bearing, and position it for installation with the tool components assembled as shown.

- The **1986-95 Taurus/Sable** application uses the larger bearing installer (No. 311885). See Fig. 5.
- The **1983-94 Tempo/Topaz and 1983-90 Escort/Lynx** applications use the smaller bearing installer (No. 311886). See Figure 5.
- The **1995-2001 Contour/Mystique** application uses bearing installer No. 314307. See Fig. 6.
- The **1991-99 Escort/Tracer** application uses bearing installer No. 314305. See Figure 6. **Important: To prevent damage to the seal lip, remove the seal before installing the bearing.**
- The **1993-99 Villager** application uses adapter No. 314309. See Fig. 6.

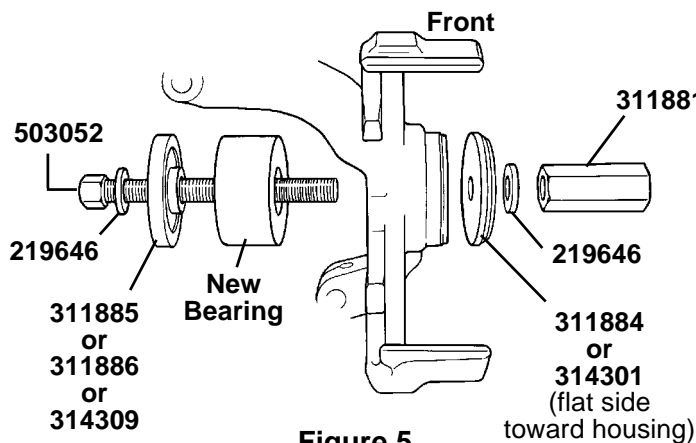

Figure 5

1986-95 Taurus / Sable
1995-98 Windstar
1983-94 Tempo / Topaz
1983-90 Escort / Lynx
1993-97 Probe
2000-04 Focus

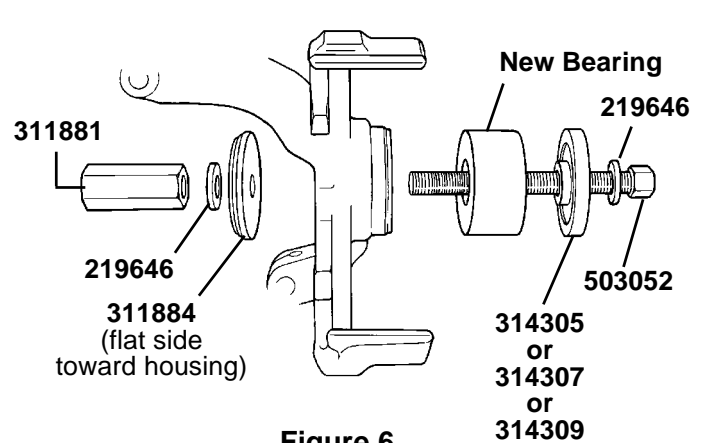

Figure 6

1995-2001 Contour / Mystique
1991-99 Escort / Tracer
1993-99 Villager

5. Press the bearing into the spindle assembly until it bottoms. Install the snap ring that was removed from the knuckle.
6. Assemble the tool components as shown in Figure 7, and install the hub. **Important: The bearing installer must be assembled with the flat side toward the bearing and the small diameter pilot on the side away from the bearing.**

- On the **1991-99 Escort/Tracer** application, install the seal after the wheel hub has been assembled.
7. Assemble the tool components (No. 7135 or No. 7924) as shown in Figure 8, and install the vehicle axle.

Note: No. 7924 is used on 1993-newer Probe; 1995-newer Contour/Mystique; and 2000-current Focus.

8. Assemble the remaining vehicle components that were removed for bearing replacement:
 - lower ball joint to steering knuckle assembly
 - brake rotor
 - disc brake caliper
 - outer tie rod nut and tie rod
 - axle nut
 - front tires

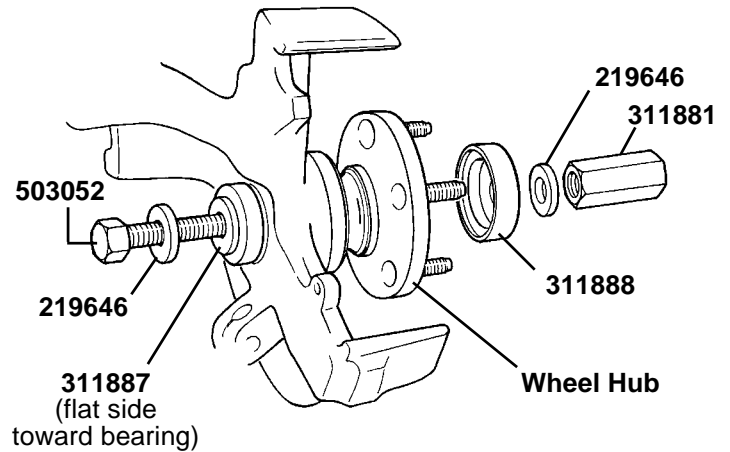

Figure 7

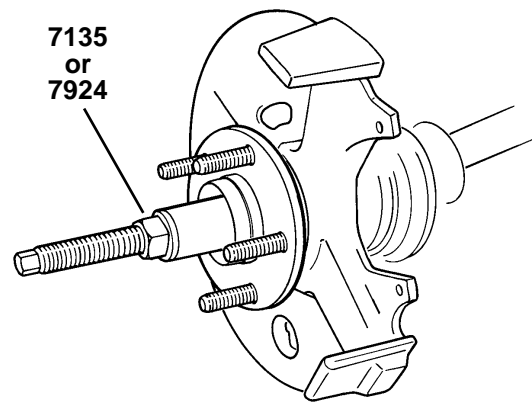

Figure 8



This page has been left blank.

General Motors

R = Remove I = Install	314299	314300	314301	314302	314304	314305	314306	314307	314308	314309	314310	314311	311882	311883	311884	311885	311886	311887	311888
All General Motors vehicles with front wheel drive																			

Bearing Removal and Installation

1. Prepare the vehicle by removing all components listed in the *HubTamer Instructions* section EXCEPT THE LOWER BALL JOINT. Do not separate the lower ball joint from the spindle assembly.
2. Remove the three retaining bolts that hold the hub assembly.
3. Remove the hub assembly from the steering knuckle using a slide hammer (OTC No. 1155; not included) and hub puller (OTC No. 7208A; not included), if necessary. See Figure 1.
4. Lightly oil the replacement hub / bearing assembly. Press the hub / bearing assembly into the spindle assembly by evenly tightening the three retaining bolts.
5. Assemble the remaining vehicle components that were removed for bearing replacement:
 - brake rotor
 - disc brake caliper
 - outer tie rod nut and tie rod
 - axle nut
 - front tires

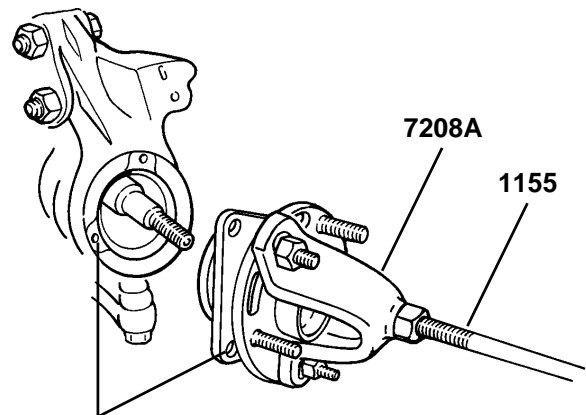

Retaining Bolt Holes

Figure 1



This page has been left blank.

Saturn

R = Remove I = Install	314299	314300	314301	314302	314304	314305	314306	314307	314308	314309	314310	314311	311882	311883	311884	311885	311886	311887	311888
1991-99 SC, SC1, SC2, SL, SL1, SL2, SW1, SW2													R		RI		I	RI	I

1. Determine if the vehicle has a trapped rotor or a floating rotor. Refer to the corresponding *HubTamer Instructions* section of this manual to remove the hub.
2. Assemble the tool components as shown in Figure 1. Hold the forcing screw with a wrench, and press the worn bearing out as shown in Figure 2.

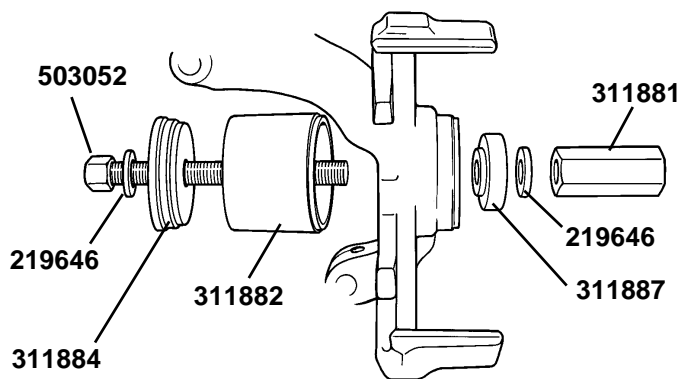

Figure 1

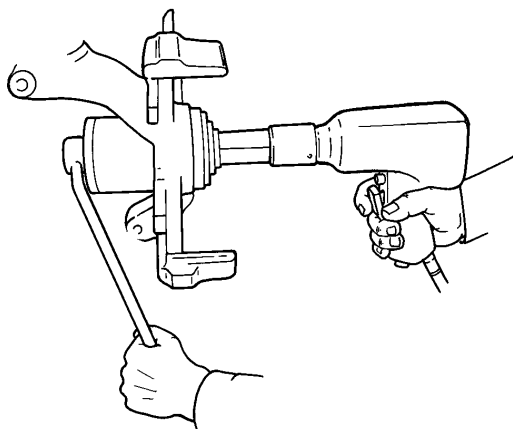

Figure 2

3. Lightly lubricate the new bearing, and position it for installation with the tool components assembled as shown in Figure 3. **Important: Assemble the adapter with the flat side toward the housing, and the small diameter pilot on the side away from the housing.**
4. Press the bearing into the spindle assembly until it bottoms. Install the snap ring.
5. Assemble the tool components as shown in Figure 4, and install the hub. **Important: The bearing installer must be assembled with the flat side toward the bearing and the small diameter pilot on the side away from the bearing.**

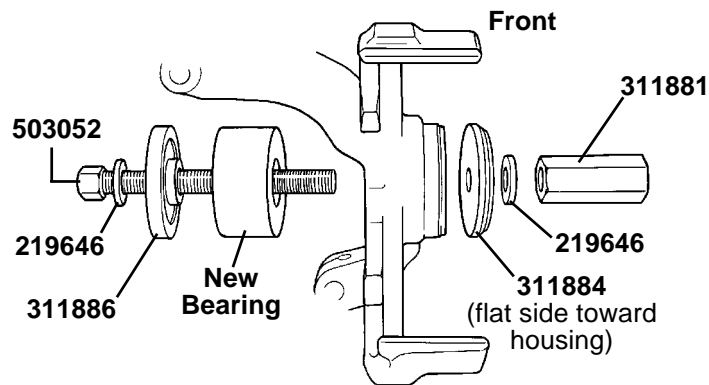

Figure 3

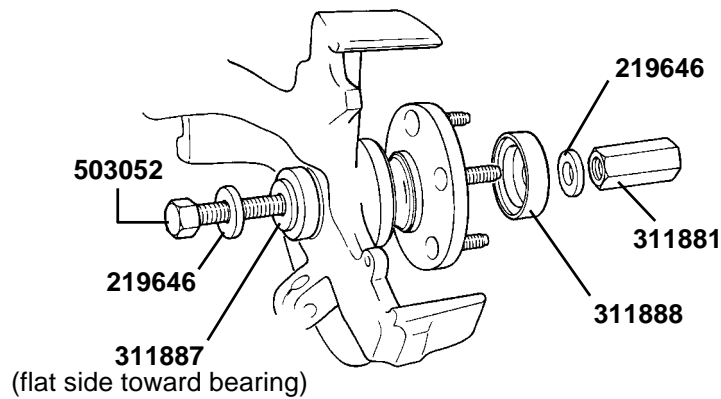

Figure 4

HubTamer Elite

No. 6537



Front Wheel Drive Service Tool Set

Section 3: Vehicle Specific Operating Instructions - Import



Table of Contents

Section 1

Parts List	1
Safety Precautions	2
HubTamer Instructions—Floating (Removable) Rotors . . .	3
HubTamer Instructions—Trapped Rotors	7

Section 2 – Domestic Vehicles

Chrysler / Plymouth / Dodge	11
Ford / Mercury	13
General Motors	17
Saturn	19

Section 3 – Import Vehicles

Acura	21
Audi	23
Eagle	25
Geo	27
Honda	29
Hyundai	31
Infiniti	33
Lexus	35
Mazda	37
Mitsubishi	39
Nissan	41
Subaru	43
Toyota	45
Volkswagen	47
Warranty Information	Inside Back Cover

Acura

R = Remove I = Install	314299	314300	314301	314302	314304	314305	314306	314307	314308	314309	314310	314311	311882	311883	311884	311885	311886	311887	311888
1986 Legend 1987 Legend (sedan) 1990-93 Integra 1991-03 NSX 1995-99 2.5 TL, 3.0 CL 1996-99 2.2 CL, 2.3 CL	R		RI							I								RI	I
1986-89 Integra			I	RI		I							R		R				I
1987 Legend (coupe) 1988-90 Legend 1992-94 Vigor		R	RI						I									RI	I
1991-99 Legend, 3.2 TC 1991-03 3.5 RL 2002-03 RSX		R	RI									I						RI	I
1999-03 3.2		R	RI								I							RI	I
1994-01 Integra	R		RI							I								RI	I

Bearing Removal and Installation

1. Determine if the vehicle has a trapped rotor or a floating rotor. Refer to the corresponding *HubTamer Instructions* section of this manual to remove the hub.
2. Assemble tool components as shown in Figure 1.
3. Hold the forcing screw with a wrench, and press out the worn bearing as shown in Figure 2.

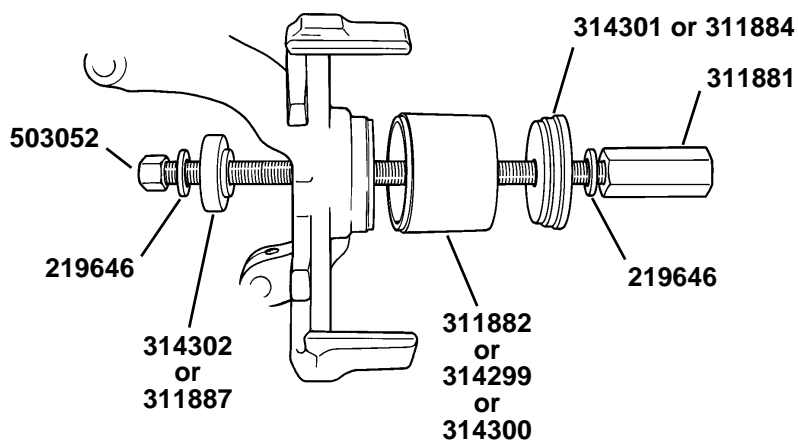

Figure 1

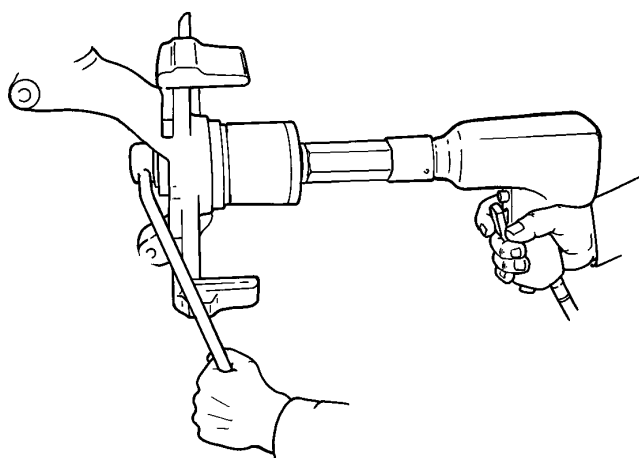
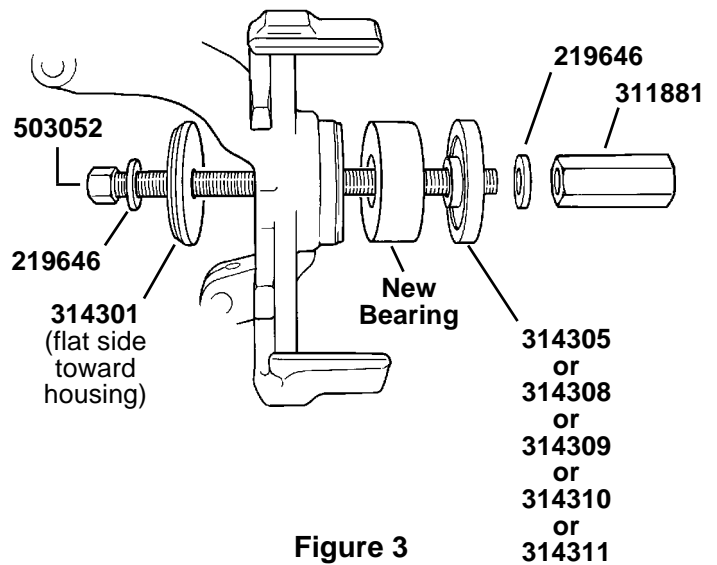
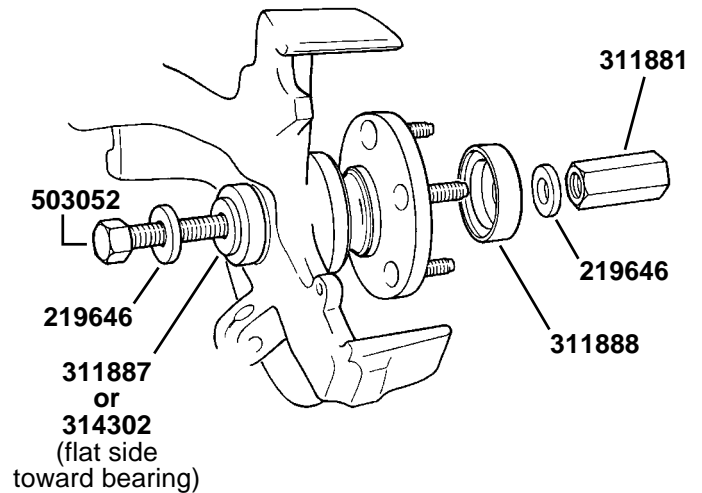

Figure 2

4. Lightly lubricate the new bearing, and position it for installation with the tool components assembled as shown in Figure 3. **Important: Assemble the adapter with the flat side toward the housing, and the small diameter pilot on the side away from the housing.**
5. Press the bearing into the spindle assembly until it bottoms. Install the snap ring.



6. Assemble tool components as shown in Figure 4, and install the hub. **Important: Assemble the bearing installer with the flat side toward the bearing, and the small diameter pilot on the side away from the bearing.**
7. Assemble the remaining vehicle components that were removed for bearing replacement:
 - lower ball joint to steering knuckle assembly
 - brake rotor
 - disc brake caliper
 - outer tie rod nut and tie rod
 - axle nut
 - front tires



Audi

R = Remove I = Install	314299	314300	314301	314302	314304	314305	314306	314307	314308	314309	314310	314311	311882	311883	311884	311885	311886	311887	311888
1980-86 Quattro, 5000, 5000 Quattro 1986-88 5000, 5000 Quattro 1989-90 100, 200 (ATX) 1991 100, 200 (ATX 3 speed)			I					I					R		R			RI	I
1980-87 Coupe, 4000, 4000 Coupe 1988 80 series			I											R	R		I	RI	I
1988-94 Quattro (coupe), 80 series, 80 Quattro, 90 series, 90 Quattro			I					I					R		R		I	RI	I
1989-93 100, 200 (MTX), V8 Quattro, 100 Quattro, 200 Quattro 1991 100, 200 (ATX 4 speed) 1992-99 S4, V8 Quattro, 100, 100 Quattro 1996-03 A4 1992-03 A6, S6 1992-04 A8, Quattro	R		RI								I							RI	I
1996-02 A4 Exc Quattro		R	RI									I						RI	I

Bearing Removal and Installation

1. Determine if the vehicle has a trapped rotor or a floating rotor. Refer to the corresponding *HubTamer Instructions* section of this manual to remove the hub.
2. Assemble tool components as shown in Figure 1.
3. Hold the forcing screw with a wrench, and press out the worn bearing as shown in Figure 2.

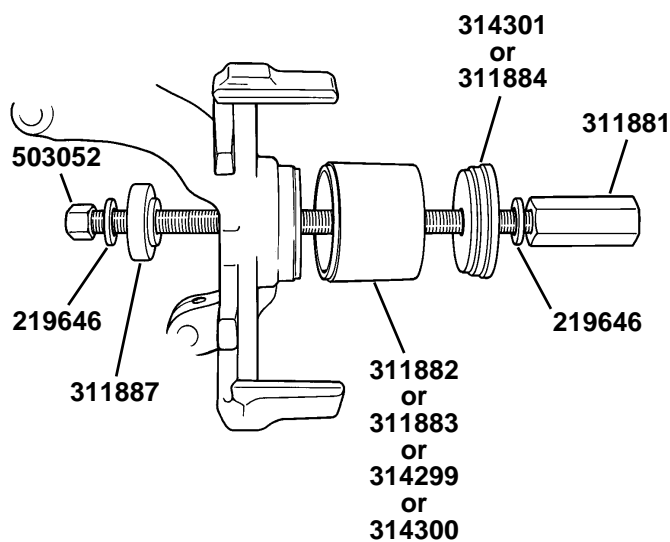

Figure 1

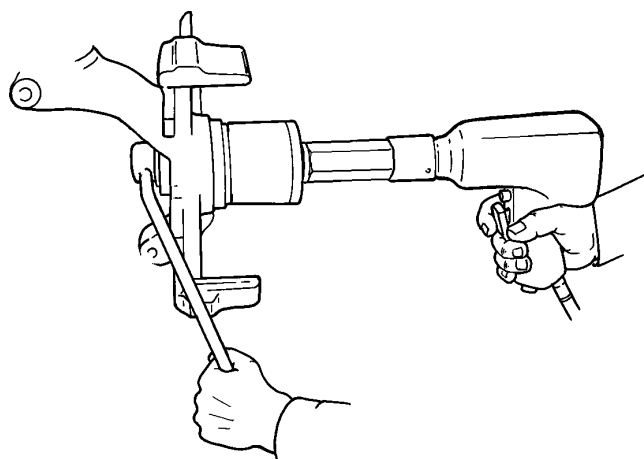

Figure 2

4. Lightly lubricate the new bearing, and position it for installation with the tool components assembled as shown in Figure 3. **Important: Assemble the adapter with the flat side toward the housing, and the small diameter pilot on the side away from the housing.**
5. Press the bearing into the spindle assembly until it bottoms. Install the snap ring.
6. Assemble the tool components as shown in Figure 4 to install the hub. **Important: Assemble the bearing installer with the flat side toward the bearing and the small diameter pilot on the side away from the bearing.**
7. Assemble the remaining vehicle components that were removed for bearing replacement:
 - lower ball joint to steering knuckle assembly
 - brake rotor
 - disc brake caliper
 - outer tie rod nut and tie rod
 - axle nut
 - front tires

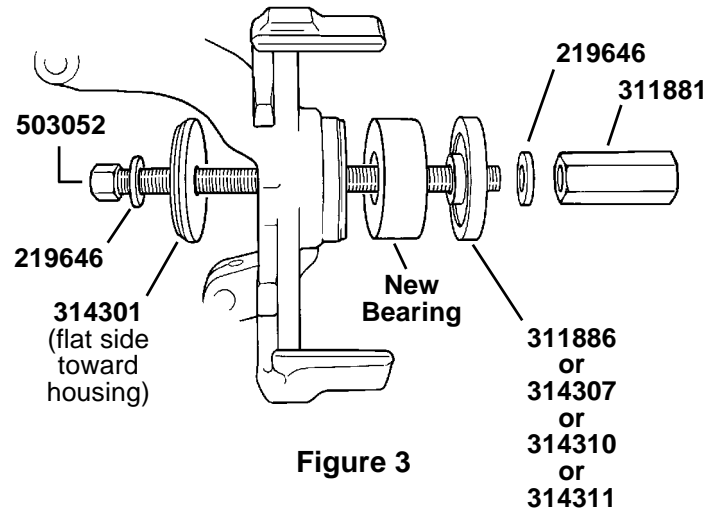

Figure 3

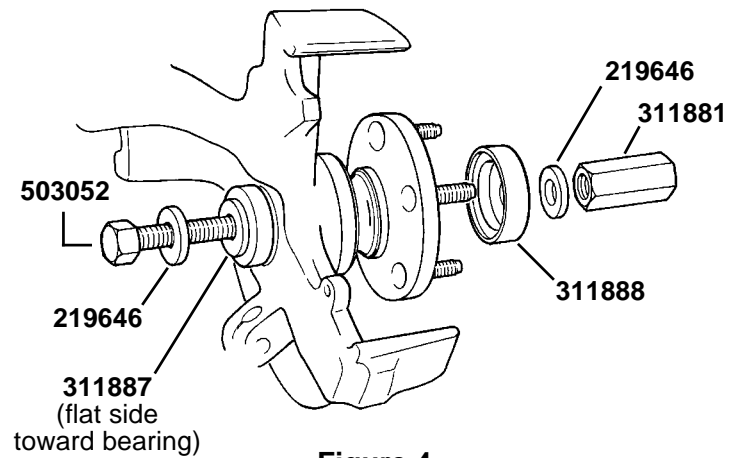

Figure 4

Eagle

R = Remove I = Install	314299	314300	314301	314302	314304	314305	314306	314307	314308	314309	314310	314311	311882	311883	311884	311885	311886	311887	311888
1993-96 Summit 1992-96 Summit Wagon 1990-94 Talon	R		RI													I		RI	I

Bearing Removal and Installation

1. Determine if the vehicle has a trapped rotor or a floating rotor. Refer to the corresponding *HubTamer Instructions* section of this manual to remove the hub.
2. Assemble tool components as shown in Figure 1.
3. Hold the forcing screw with a wrench, and press out the worn bearing as shown in Figure 2.

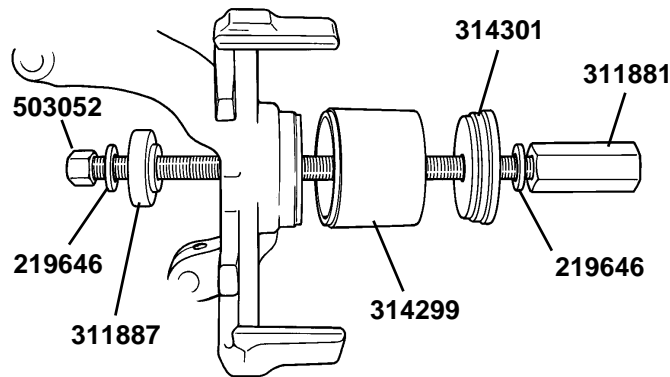

Figure 1

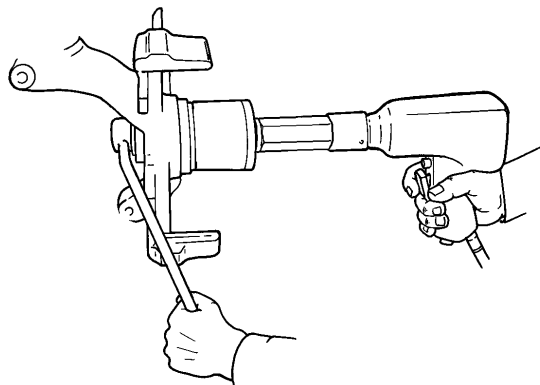

Figure 2

4. Lightly lubricate the new bearing, and position it for installation with the tool components assembled as shown in Figure 3. **Important: Assemble the adapter with the flat side toward the housing, and the small diameter pilot on the side away from the housing.**
5. Press the bearing into the spindle assembly until it bottoms. Install the snap ring.
6. Assemble tool components as shown in Figure 4, and install the hub. **Important: Assemble the bearing installer with the flat side toward the bearing, and the small diameter pilot on the side away from the bearing.**

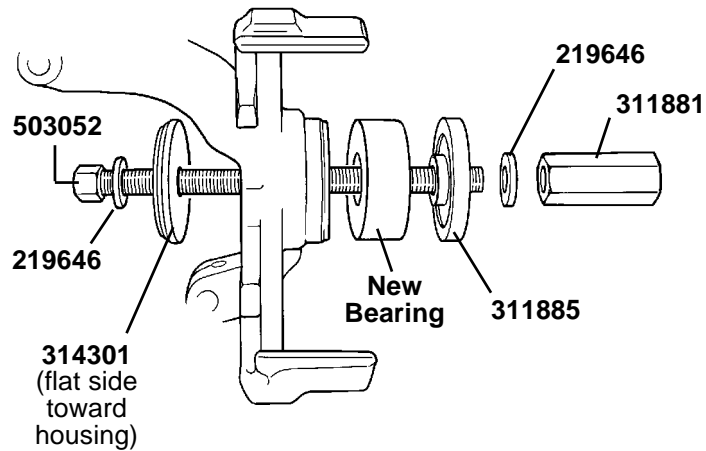

Figure 3

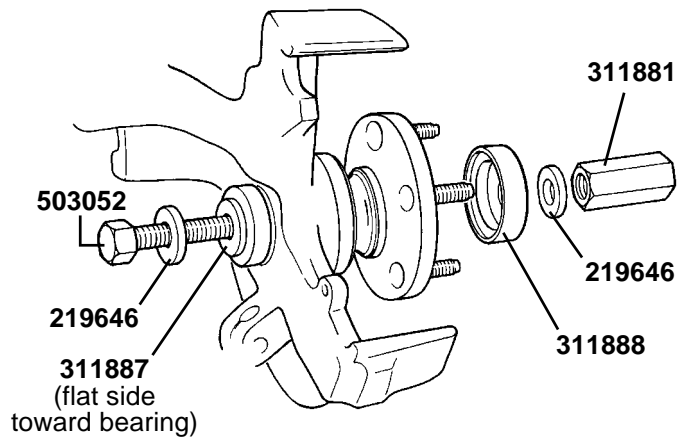

Figure 4

Geo

	314299	314300	314301	314302	314304	314305	314306	314307	314308	314309	314310	314311	311882	311883	311884	311885	311886	311887	311888
R = Remove I = Install																			
1989-97 Prizm 1995-98 Metro														R	RI			RI	I

Bearing Removal and Installation

1. Determine if the vehicle has a trapped rotor or a floating rotor. Refer to the corresponding *HubTamer Instructions* section of this manual to remove the hub.
2. Assemble tool components as shown in Figure 1.
3. Hold the forcing screw with a wrench, and press out the worn bearing as shown in Figure 2.

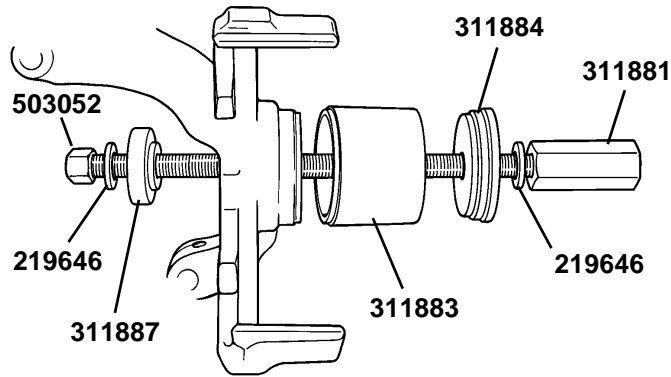

Figure 1

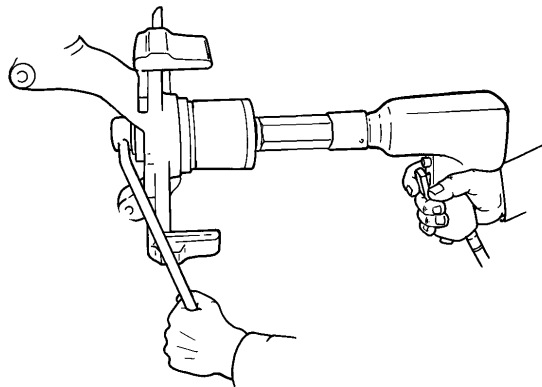

Figure 2

4. Lightly lubricate the new bearing, and position it for installation with the tool components assembled as shown in Figure 3. **Important: Assemble the adapter with the flat side toward the housing, and the small diameter pilot on the side away from the housing.**
5. Press the bearing into the spindle assembly until it bottoms. Install the snap ring.
6. Assemble tool components as shown in Figure 4, and install the hub. **Important: Assemble the bearing installer with the flat side toward the bearing, and the small diameter pilot on the side away from the bearing.**

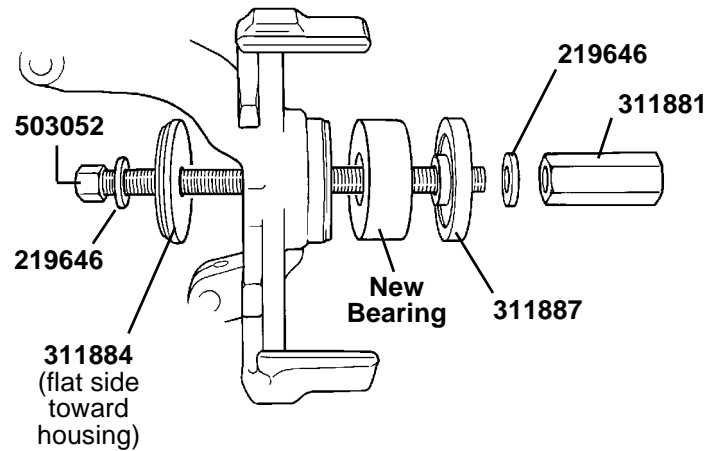

Figure 3

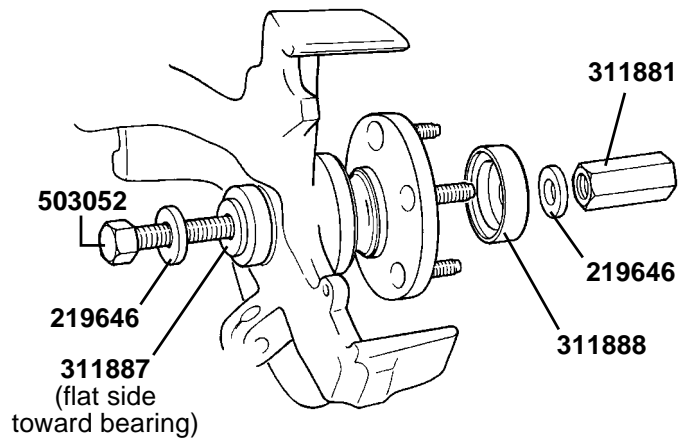

Figure 4

Honda

R = Remove I = Install	314299	314300	314301	314302	314304	314305	314306	314307	314308	314309	314310	314311	311882	311883	311884	311885	311886	311887	311888
1980-85 Accord 1980-87 Prelude				RI									R		RI				I
1984-91 Civic, CRX, Civic Wagon 4WD				I									R		RI			RI	I
1986-89 Accord 1992-99 Civic, del Sol						I							R		RI	I		RI	I
1988-96 Prelude	R		RI						I			I						RI	I
1996-00 Civic Exc., Ex, Si						I							R		RI			RI	I
1992-96 Prelude 2003 Accord		R	RI									I						RI	I
2001-03 Civic 1996-00 Civic Ex, Si 1994-97 del Sol 1992-95 Civic w/ABS	R		RI							I								RI	I
2000-03 S2000 1997-01 Prelude		R	RI									I						RI	I
1999-03 Odyssey		R	RI						I									RI	I
1998-02 Accord		R	RI									I						RI	I
1995-98 Odyssey 1990-97 Accord	Refer to <i>HubTamer Instructions – Trapped Rotors</i> .																		

Bearing Removal and Installation

1. Determine if the vehicle has a trapped rotor or a floating rotor. Refer to the corresponding *HubTamer Instructions* section of this manual to remove the hub.

Note: Some Honda vehicles use a bolt-in bearing instead of a pressed-in bearing. Refer to *HubTamer Instructions - Trapped Rotors* to service these bearings.

2. Assemble tool components as shown in Figure 1.

3. Hold the forcing screw with a wrench, and press out the worn bearing as shown in Figure 2.

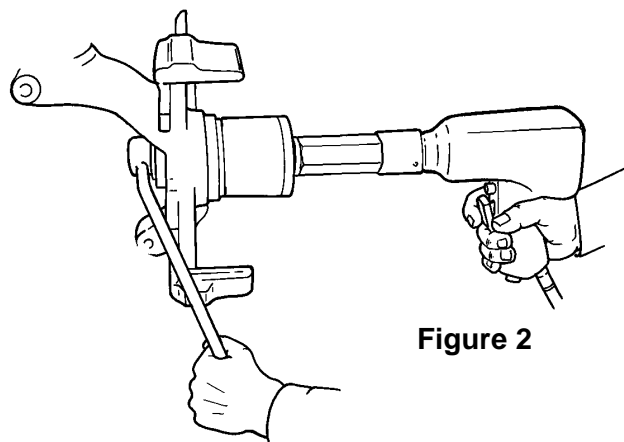
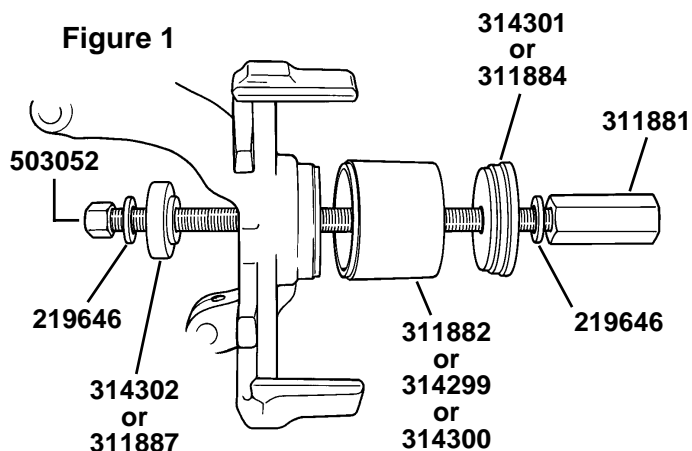

4. Lightly lubricate the new bearing, and position it for installation with the tool components assembled as shown in Figure 3. **Important: Assemble the adapter with the flat side toward the housing, and the small diameter pilot on the side away from the housing.**
5. Press the bearing into the spindle assembly until it bottoms. Install the snap ring.
6. Assemble tool components as shown in Figure 4, and install the hub. **Important: Assemble the bearing installer with the flat side toward the bearing, and the small diameter pilot on the side away from the bearing.**

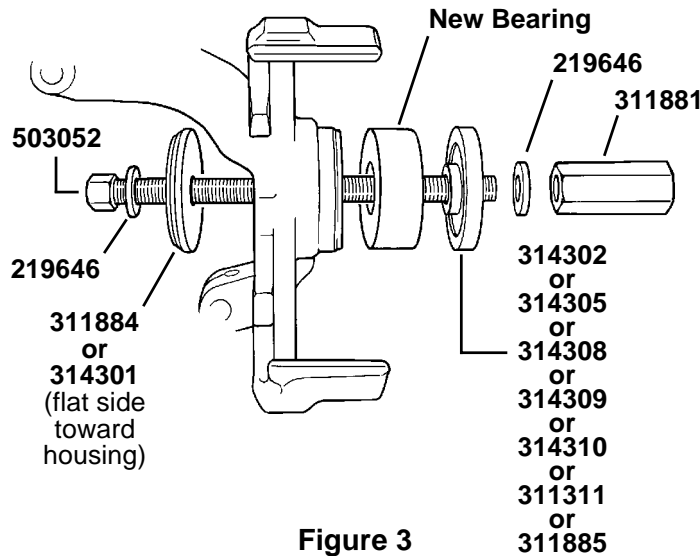

Figure 3

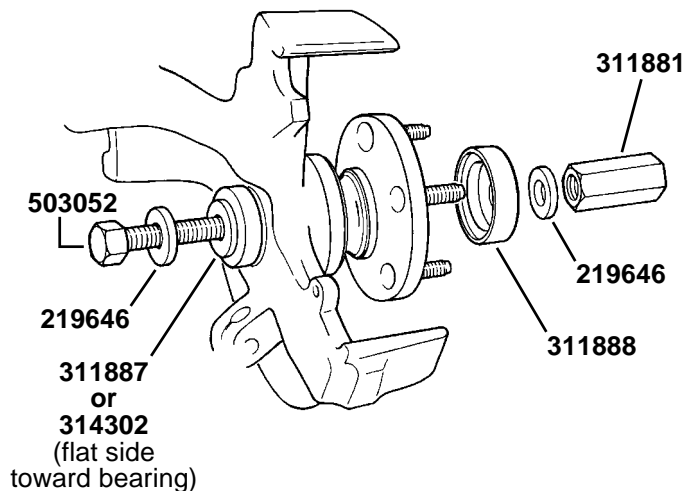

Figure 4

Hyundai

R = Remove I = Install	314299	314300	314301	314302	314304	314305	314306	314307	314308	314309	314310	314311	311882	311883	311884	311885	311886	311887	311888
1986-95 Elantra, Scoupe 1995-1999 Accent					I								R		RI			RI	I
1989-94 Sonata		R	RI							I								RI	I
2001-02 Santa Fe		R	RI									I						RI	I
1999-02 Sonata	R		RI							I								RI	I
2000-02 Accent 1996-02 Elantra 1997-01 Triburon													R		RI		I	RI	I

Bearing Removal and Installation

1. Determine if the vehicle has a trapped rotor or a floating rotor. Refer to the corresponding *HubTamer Instructions* section of this manual to remove the hub.
2. Assemble tool components as shown in Figure 1.
3. Hold the forcing screw with a wrench, and press out the worn bearing as shown in Figure 2.

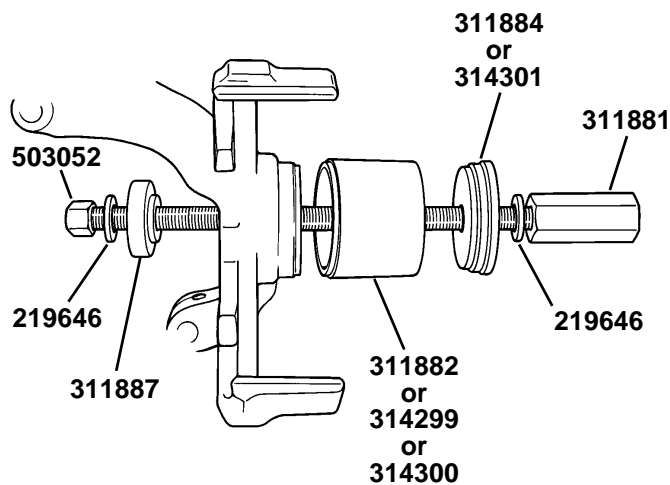

Figure 1

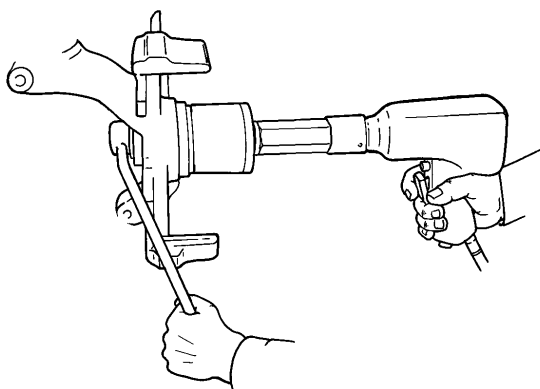

Figure 2

4. Lightly lubricate the new bearing, and position it for installation with the tool components assembled as shown in Figure 3. **Important: Assemble the adapter with the flat side toward the housing, and the small diameter pilot on the side away from the housing.**
5. Press the bearing into the spindle assembly until it bottoms. Install the snap ring.
6. Assemble tool components as shown in Figure 4, and install the hub. **Important: Assemble the bearing installer with the flat side toward the bearing, and the small diameter pilot on the side away from the bearing.**

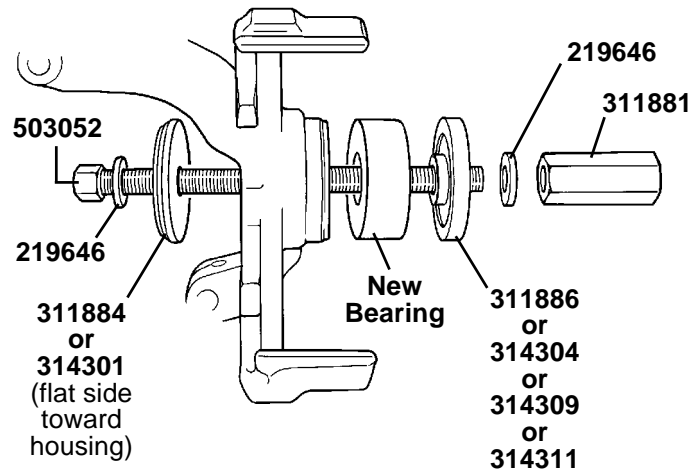

Figure 3

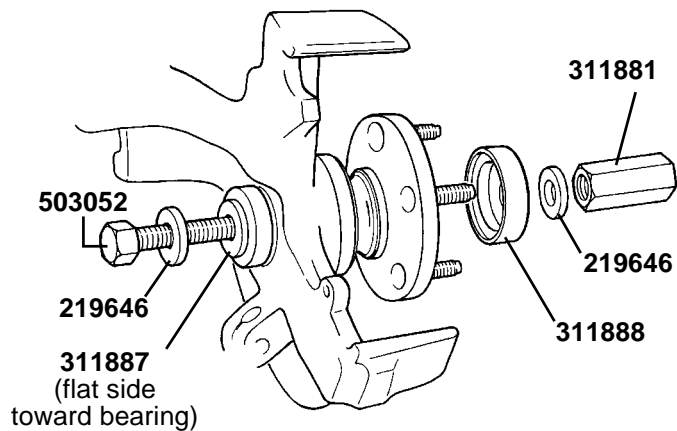

Figure 4

Infiniti

	314299	314300	314301	314302	314304	314305	314306	314307	314308	314309	314310	314311	311882	311883	311884	311885	311886	311887	311888
R = Remove I = Install								I					R		RI			RI	I
1991-02 G20 1996-01 I30																			

Bearing Removal and Installation

1. Determine if the vehicle has a trapped rotor or a floating rotor. Refer to the corresponding *HubTamer Instructions* section of this manual to remove the hub.
2. Assemble tool components as shown in Figure 1.
3. Hold the forcing screw with a wrench, and press out the worn bearing as shown in Figure 2.

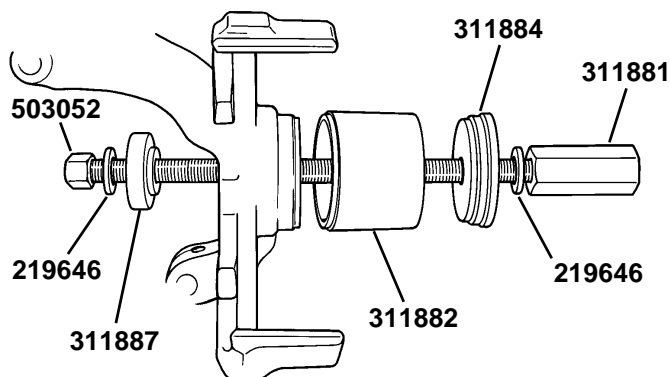

Figure 1

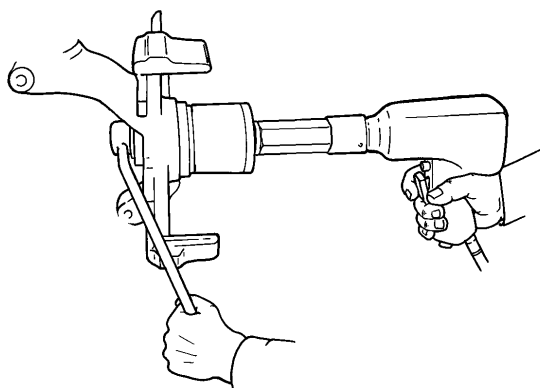

Figure 2

4. Lightly lubricate the new bearing, and position it for installation with the tool components assembled as shown in Figure 3. **Important: Assemble the adapter with the flat side toward the housing, and the small diameter pilot on the side away from the housing.**
5. Press the bearing into the spindle assembly until it bottoms. Install the snap ring.
6. Assemble tool components as shown in Figure 4, and install the hub. **Important: Assemble the bearing installer with the flat side toward the bearing, and the small diameter pilot on the side away from the bearing.**

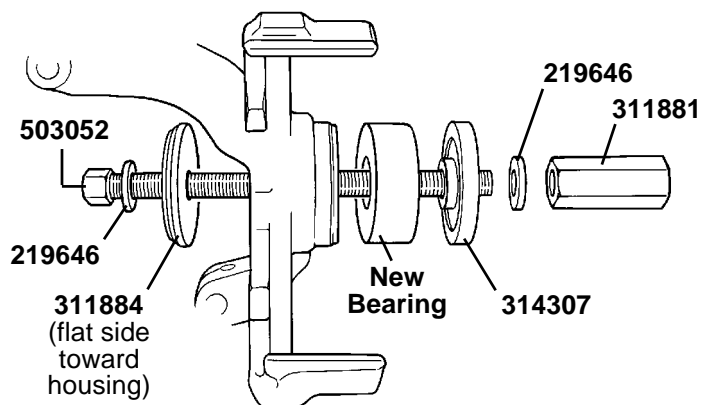

Figure 3

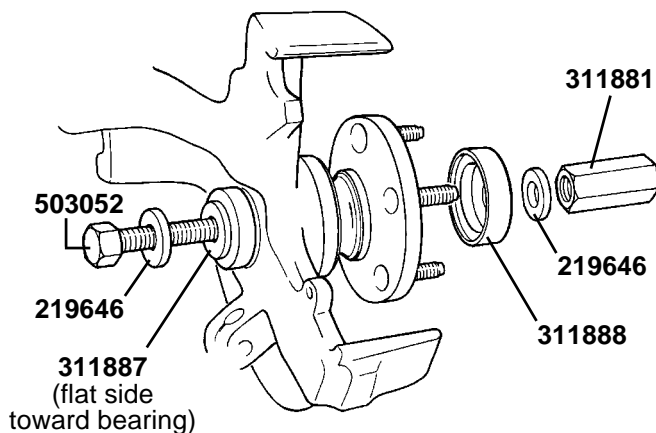

Figure 4

Lexus

R = Remove I = Install	314299	314300	314301	314302	314304	314305	314306	314307	314308	314309	314310	314311	311882	311883	311884	311885	311886	311887	311888	
1989-91 ES250					I	I		I					R		RI				RI	I
1992-02 ES300	R		RI								I								RI	I

Bearing Removal and Installation

1. Determine if the vehicle has a trapped rotor or a floating rotor. Refer to the corresponding *HubTamer Instructions* section of this manual to remove the hub.
2. Assemble tool components as shown in Figure 1.
3. Hold the forcing screw with a wrench, and press out the worn bearing as shown in Figure 2.

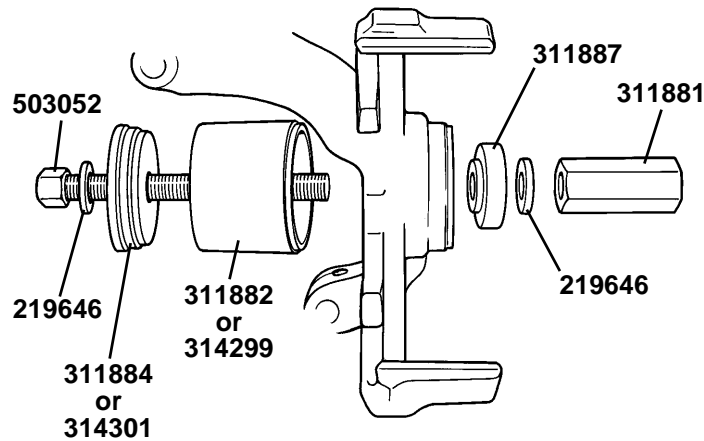

Figure 1

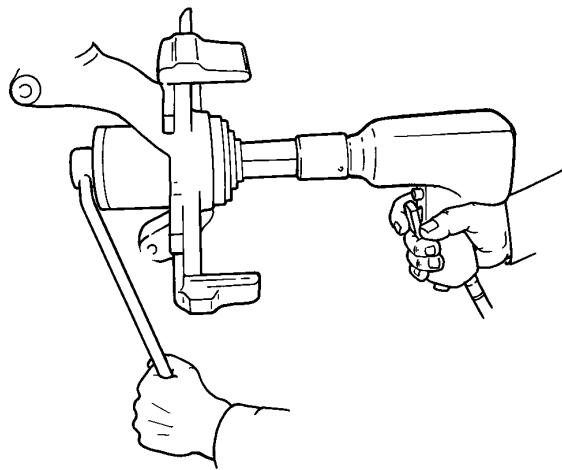

Figure 2

4. Lightly lubricate the new bearing, and position it for installation with the tool components assembled as shown in Figure 3. **Important: Assemble the adapter with the flat side toward the housing, and the small diameter pilot on the side away from the housing.**
5. Press the bearing into the spindle assembly until it bottoms. Install the snap ring.
6. Assemble tool components as shown in Figure 4, and install the hub. **Important: Assemble the bearing installer with the flat side toward the bearing, and the small diameter pilot on the side away from the bearing.**

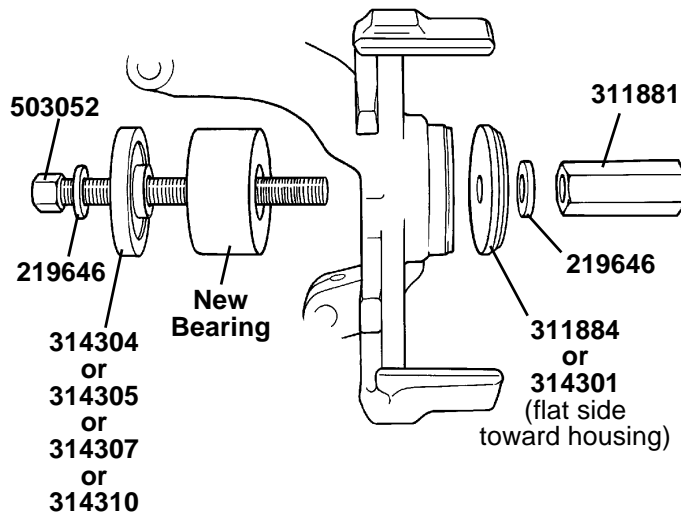

Figure 3

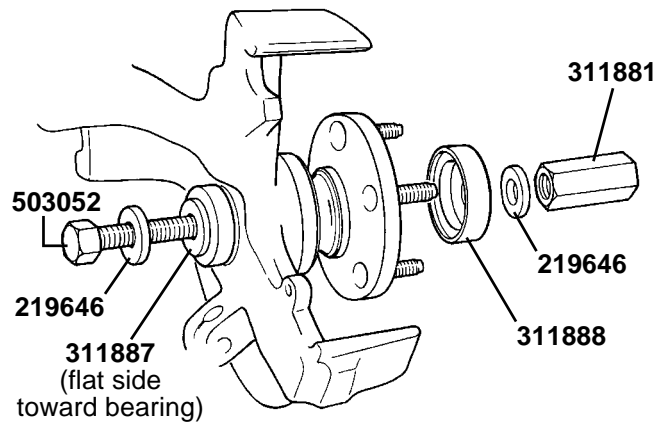

Figure 4

Mazda

R = Remove I = Install	314299	314300	314301	314302	314304	314305	314306	314307	314308	314309	314310	314311	311882	311883	311884	311885	311886	311887	311888
1983-87 626														R	RI		I	RI	I
1988-92 MX6, 626							I						R		RI			RI	I
1990-99 MX3, Protege, 323								I					R		RI			RI	I
1993-99 Millenia, MX6, 626	R		RI							I								RI	I
1993-03 626, MX6 1996-00 Millenia										I			R		RI			RI	I
1998-02 Protege								I					R		RI			RI	I

Bearing Removal and Installation

1. Determine if the vehicle has a trapped rotor or a floating rotor. Refer to the corresponding *HubTamer Instructions* section of this manual to remove the hub.
2. Assemble tool components as shown in Figure 1.
3. Hold the forcing screw with a wrench, and press out the worn bearing as shown in Figure 2.

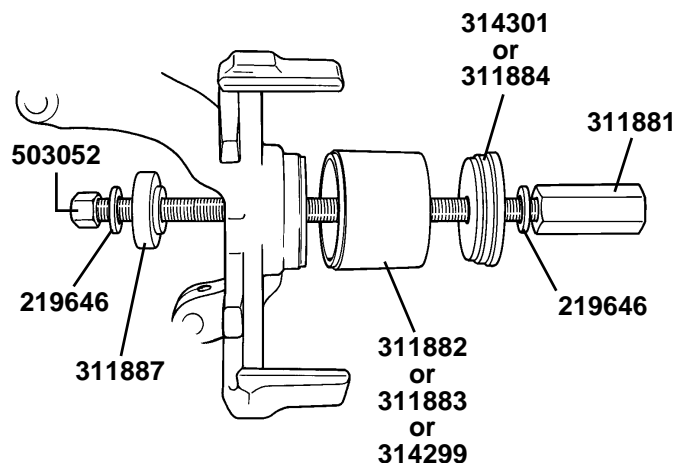

Figure 1

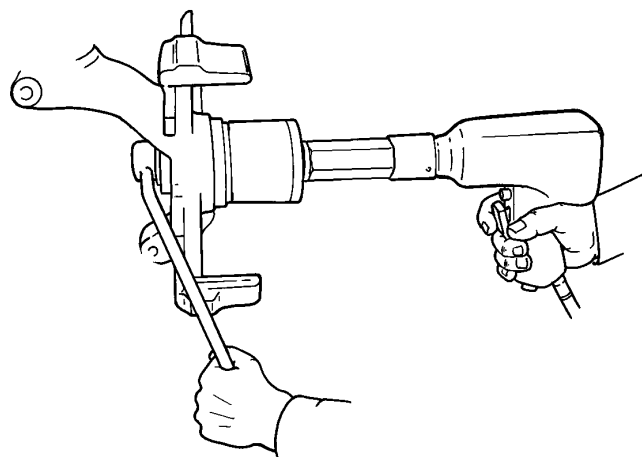

Figure 2

4. Lightly lubricate the new bearing, and position it for installation with the tool components assembled as shown in Figure 3. **Important: Assemble the adapter with the flat side toward the housing, and the small diameter pilot on the side away from the housing.**
5. Press the bearing into the spindle assembly until it bottoms. Install the snap ring.
6. Assemble tool components as shown in Figure 4, and install the hub. **Important: Assemble the bearing installer with the flat side toward the bearing, and the small diameter pilot on the side away from the bearing.**

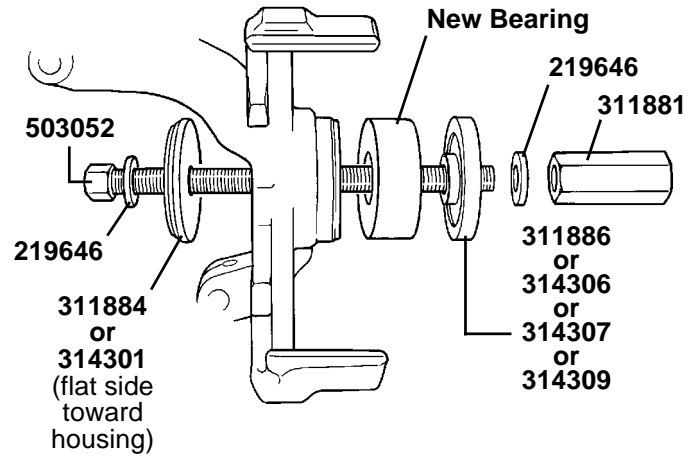

Figure 3

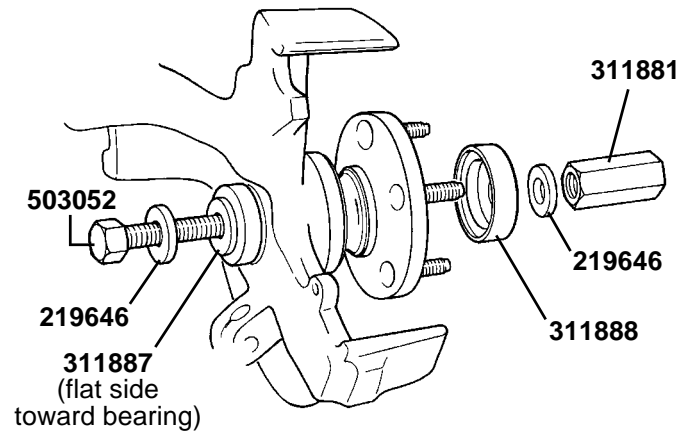

Figure 4

Mitsubishi

R = Remove I = Install	314299	314300	314301	314302	314304	314305	314306	314307	314308	314309	314310	314311	311882	311883	311884	311885	311886	311887	311888
1990-03 Diamante 1992-02 Mirage 1989-94 Eclipse 1985-93 Galant, Sigma 1999 3000GT		R	RI													I		RI	I

Bearing Removal and Installation

1. Determine if the vehicle has a trapped rotor or a floating rotor. Refer to the corresponding *HubTamer Instructions* section of this manual to remove the hub.
2. Assemble tool components as shown in Figure 1.
3. Hold the forcing screw with a wrench, and press out the worn bearing as shown in Figure 2.

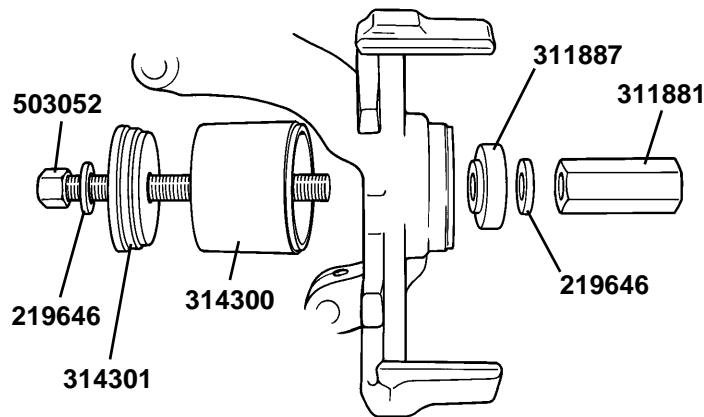

Figure 1

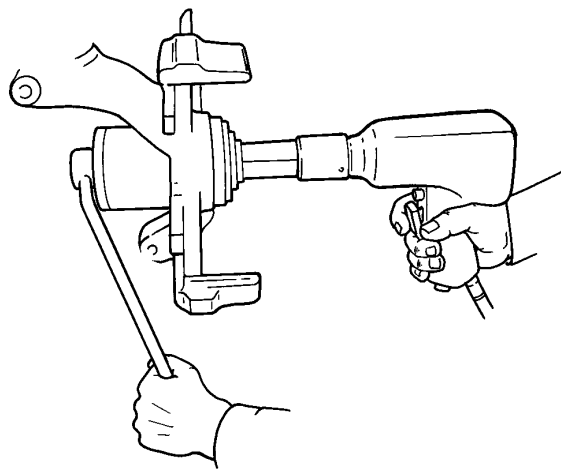

Figure 2

4. Lightly lubricate the new bearing, and position it for installation with the tool components assembled as shown in Figure 3. **Important: Assemble the adapter with the flat side toward the housing, and the small diameter pilot on the side away from the housing.**
5. Press the bearing into the spindle assembly until it bottoms. Install the snap ring.
6. Assemble tool components as shown in Figure 4, and install the hub. **Important: Assemble the bearing installer with the flat side toward the bearing, and the small diameter pilot on the side away from the bearing.**

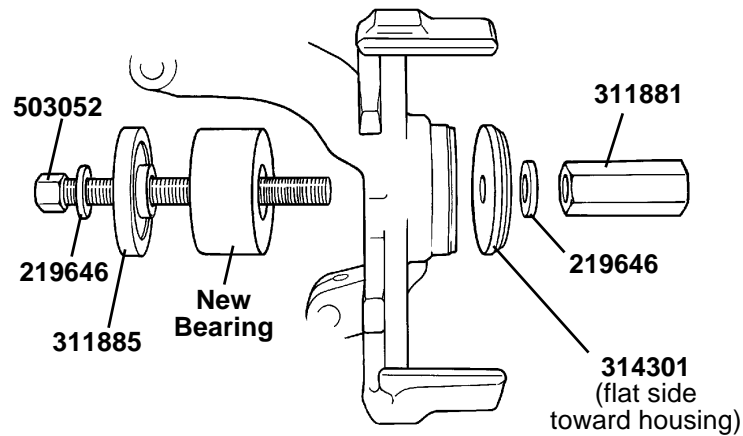

Figure 3

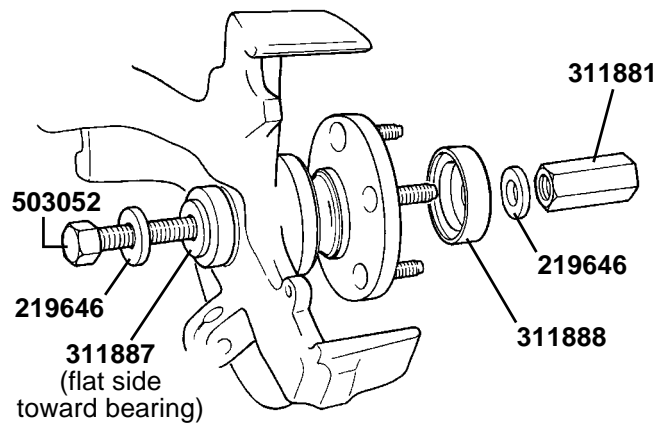

Figure 4

Nissan

R = Remove I = Install	314299	314300	314301	314302	314304	314305	314306	314307	314308	314309	314310	314311	311882	311883	311884	311885	311886	311887	311888
1987-90 Pulsar, Sentra 1991-99 NX, Sentra, 200 SX					RI			I					R		RI				I
1989 Maxima 1990-99 Altima, Maxima, Stanza 2000-01 Altima 2000-03 Sentra								I					R		RI			RI	I
1985-88 Maxima, Maxima Wagon 1985-88 Stanza, Stanza Wagon 1989 Stanza							I						R		RI			RI	I

Bearing Removal and Installation

1. Determine if the vehicle has a trapped rotor or a floating rotor. Refer to the corresponding *Hub Tamer Instructions* section of this manual to remove the hub.
2. Assemble tool components as shown in Figure 1.
3. Hold the forcing screw with a wrench, and press out the worn bearing as shown in Figure 2.

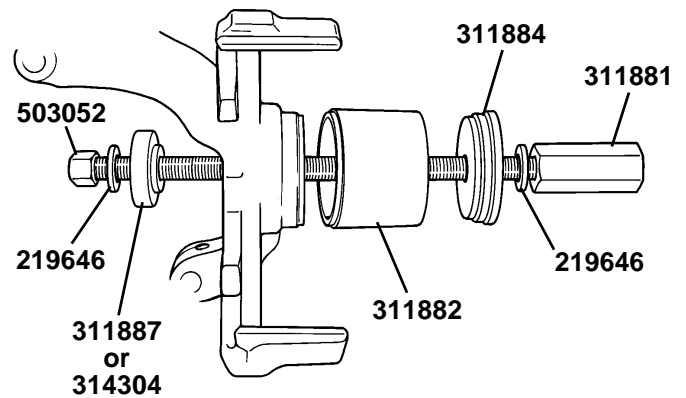

Figure 1

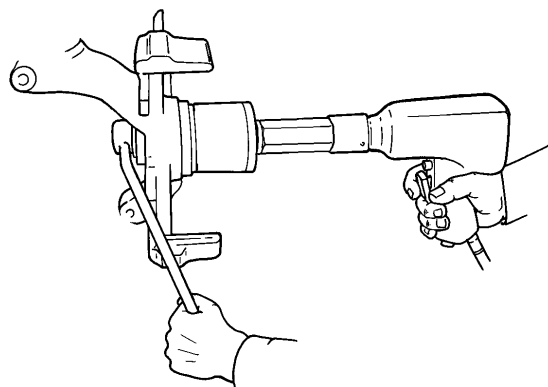

Figure 2

4. Lightly lubricate the new bearing, and position it for installation with the tool components assembled as shown in Figure 3. **Important: Assemble the adapter with the flat side toward the housing, and the small diameter pilot on the side away from the housing.**
5. Press the bearing into the spindle assembly until it bottoms. Install the snap ring.
6. Assemble tool components as shown in Figure 4, and install the hub. **Important: Assemble the bearing installer with the flat side toward the bearing, and the small diameter pilot on the side away from the bearing.**

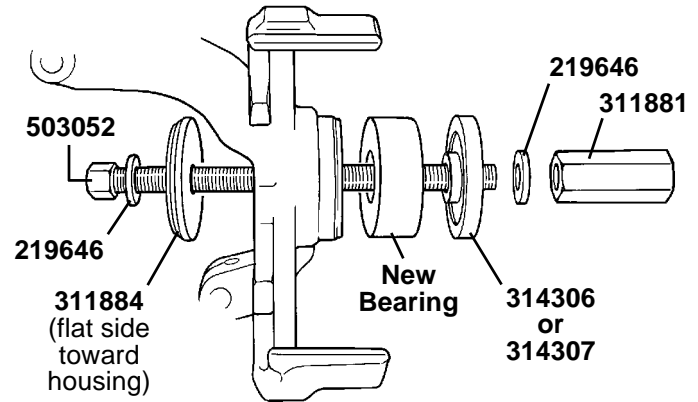

Figure 3

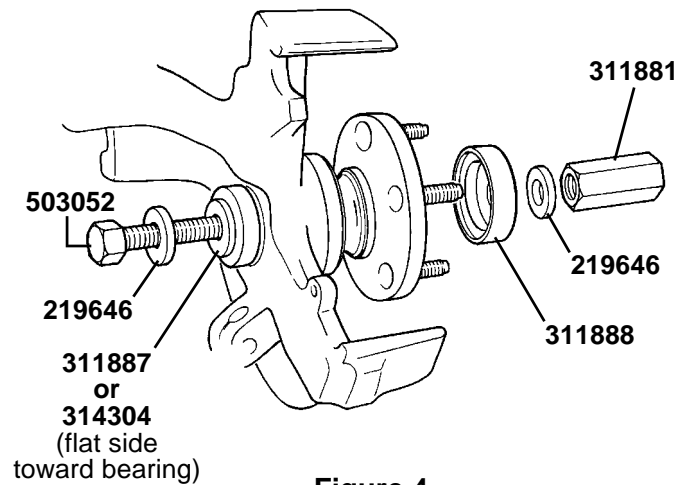

Figure 4

Subaru

R = Remove I = Install	314299	314300	314301	314302	314304	314305	314306	314307	314308	314309	314310	314311	311882	311883	311884	311885	311886	311887	311888
1994-03 Legacy 1993-03 Impreza 1992-98 SVX					I								R		RI			RI	I

Bearing Removal and Installation

1. Determine if the vehicle has a trapped rotor or a floating rotor. Refer to the corresponding *HubTamer Instructions* section of this manual to remove the hub.
2. Assemble tool components as shown in Figure 1.
3. Hold the forcing screw with a wrench, and press out the worn bearing as shown in Figure 2.

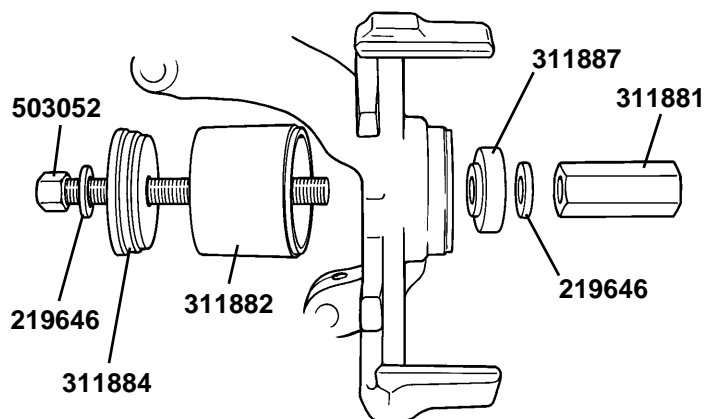

Figure 1

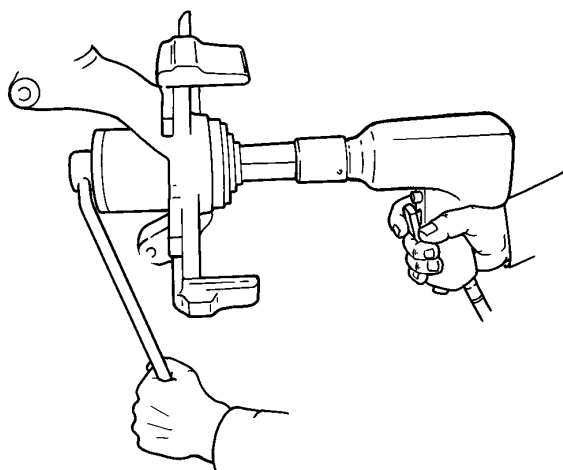

Figure 2

4. Lightly lubricate the new bearing, and position it for installation with the tool components assembled as shown in Figure 3. **Important: Assemble the adapter with the flat side toward the housing, and the small diameter pilot on the side away from the housing.**
5. Press the bearing into the spindle assembly until it bottoms. Install the snap ring.
6. Assemble tool components as shown in Figure 4, and install the hub. **Important: Assemble the bearing installer with the flat side toward the bearing, and the small diameter pilot on the side away from the bearing.**

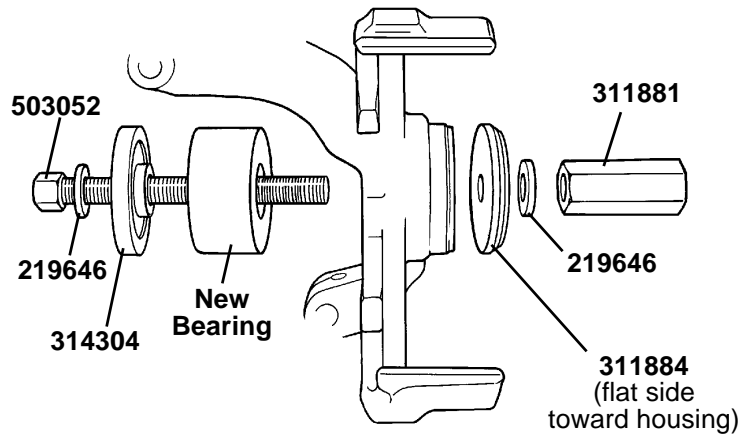

Figure 3

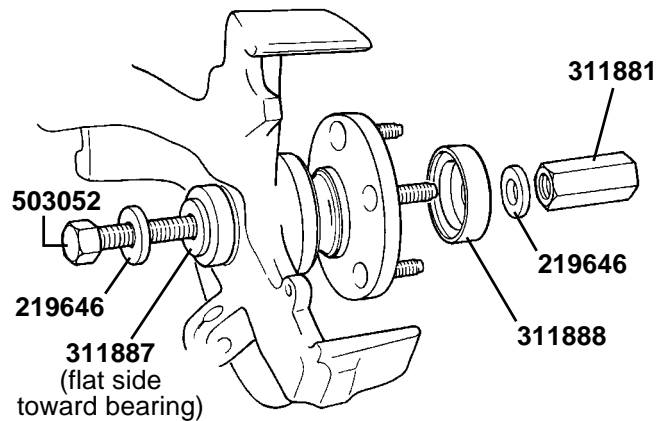

Figure 4

Toyota

R = Remove I = Install	314299	314300	314301	314302	314304	314305	314306	314307	314308	314309	314310	314311	311882	311883	311884	311885	311886	311887	311888
1983-89 Corolla FX 1983-91 Camry 1983-99 Celica 1983-99 Tercel 1987-99 Paseo 1988-02 Corolla					I	I		I					R		RI			RI	I
1992-03 Avalon, Camry	R		RI								I							RI	I
2003 Corolla 2001-03 Prius								I					R		RI			RI	I
2000-03 Echo 2000 Celica					I								R		RI			RI	I

Bearing Removal and Installation

1. Determine if the vehicle has a trapped rotor or a floating rotor. Refer to the corresponding *HubTamer Instructions* section of this manual to remove the hub.
2. Assemble tool components as shown in Figure 1.
3. Hold the forcing screw with a wrench, and press out the worn bearing as shown in Figure 2.

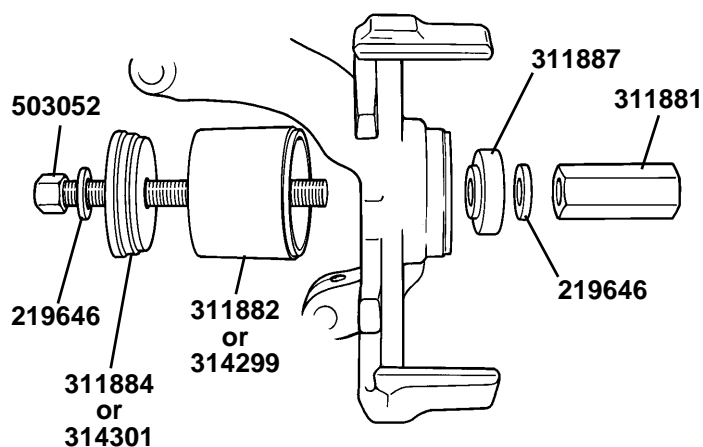

Figure 1

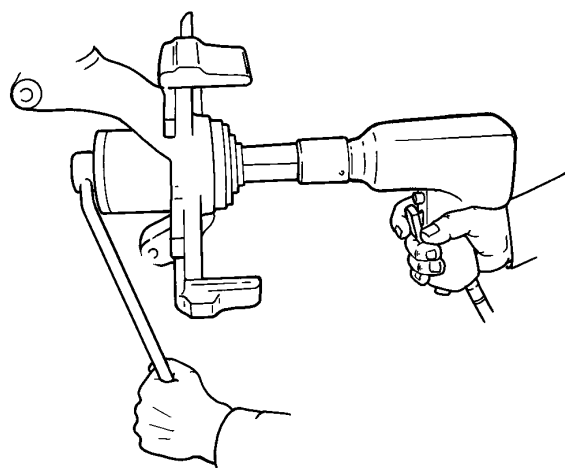

Figure 2

4. Lightly lubricate the new bearing, and position it for installation with the tool components assembled as shown in Figure 3. **Important: Assemble the adapter with the flat side toward the housing, and the small diameter pilot on the side away from the housing.**
5. Press the bearing into the spindle assembly until it bottoms. Install the snap ring.
6. Assemble tool components as shown in Figure 4, and install the hub. **Important: Assemble the bearing installer with the flat side toward the bearing, and the small diameter pilot on the side away from the bearing.**

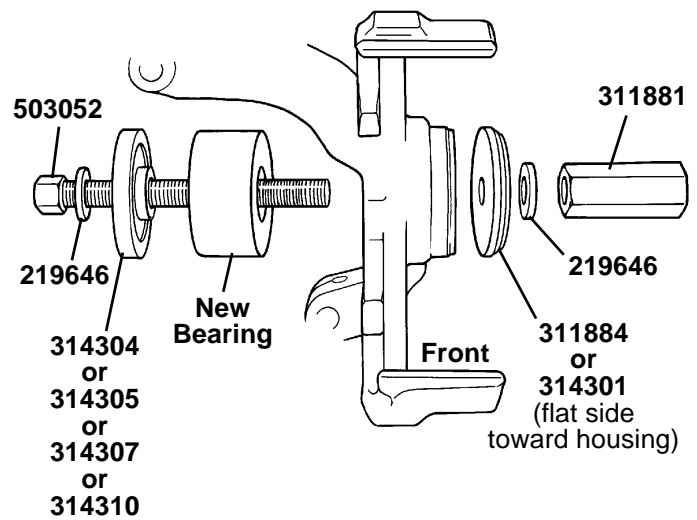

Figure 3

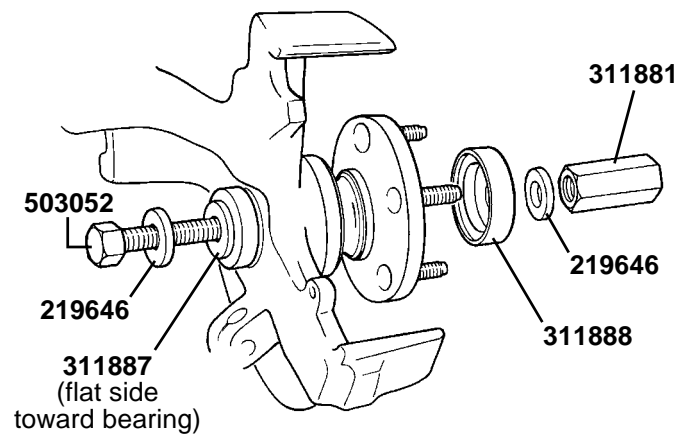

Figure 4

Volkswagen

R = Remove I = Install	314299	314300	314301	314302	314304	314305	314306	314307	314308	314309	314310	314311	311882	311883	311884	311885	311886	311887	311888
1980-84 Jetta, Rabbit 1980-96 Scirocco 1985-87 Golf, GTI, Jetta 1985-96 Cabriolet				RI										R	RI		I		I
1980-96 Dasher, Fox, Quantum, Quantum Sychro				I										R	RI			RI	I
1988-02 Golf, GTI, Jetta 1990-99 Corrado, Passat						I							R		RI			RI	I
1998-03 Passat 1992-96 Eurovan	R		RI															RI	I

Bearing Removal and Installation

1. Determine if the vehicle has a trapped rotor or a floating rotor. Refer to the corresponding *HubTamer Instructions* section of this manual to remove the hub.
2. Assemble tool components as shown in Figure 1.
3. Hold the forcing screw with a wrench, and press out the worn bearing as shown in Figure 2.

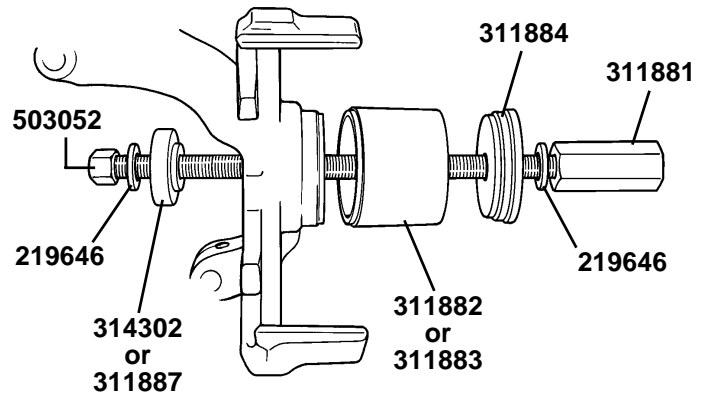

Figure 1

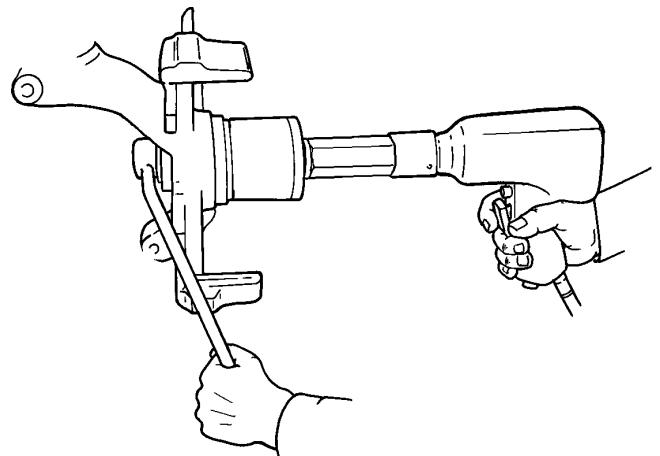

Figure 2

4. Lightly lubricate the new bearing, and position it for installation with the tool components assembled as shown in Figure 3. **Important: Assemble the adapter with the flat side toward the housing, and the small diameter pilot on the side away from the housing.**
5. Press the bearing into the spindle assembly until it bottoms. Install the snap ring.
6. Assemble tool components as shown in Figure 4, and install the hub. **Important: Assemble the bearing installer with the flat side toward the bearing, and the small diameter pilot on the side away from the bearing.**

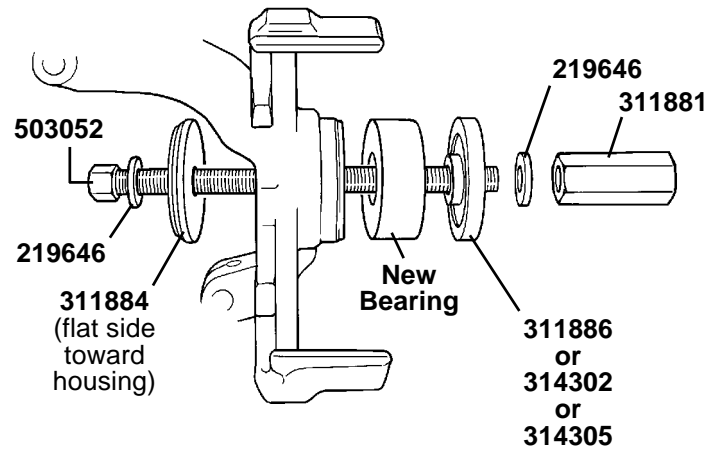

Figure 3

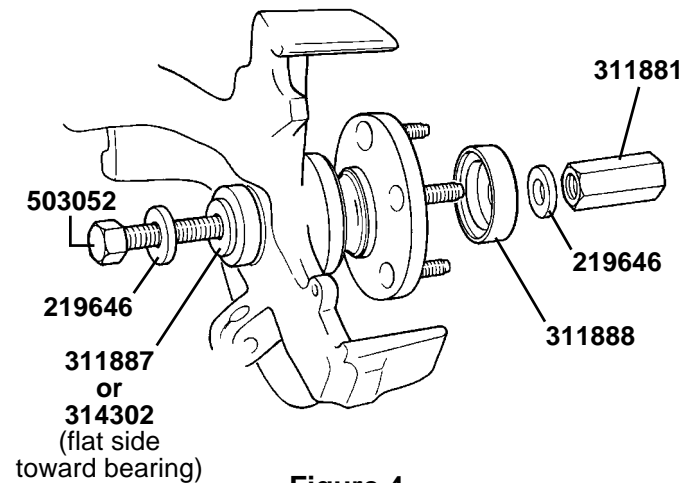

Figure 4



Lifetime Marathon Warranty®

Effective 4-1-84; Rev. 5-15-00

THIS WARRANTY IS EXPRESSLY LIMITED TO ORIGINAL RETAIL BUYERS OF SPX'S OTC BRAND PRODUCTS OR PARTS ("OTC PRODUCTS"). THIS WARRANTY IS NOT ASSIGNABLE OR TRANSFERABLE. SPX MAKES NO WARRANTY TO ANYONE ELSE, INCLUDING OTHER PURCHASERS AND/OR USERS, AND NONE SHALL BE IMPLIED.

Except as otherwise provided in this warranty, OTC Products are warranted against defects in materials and workmanship for the life of the OTC Product, meaning that point in time when the OTC Product no longer functions due to normal wear. This warranty does not apply to electronic products, which are covered by separate warranties. Nor does this warranty apply to the following items, which may be incorporated into or sold with OTC Products and which are sold "as-is" with all faults: chains, batteries, electric motors, knives, and cutter blades. (Electric motors are warranted by their manufacturers under conditions stated in their warranties.)

The sole and exclusive remedy for any OTC Product found to be defective is repair or replacement, at the option of SPX. If this exclusive remedy is deemed to have failed of its essential purpose, SPX's liability shall not exceed the purchase price of the OTC Product. In no event will SPX be liable for any direct, indirect, special, incidental, or consequential damages (including lost profit) whether based on warranty, contract, tort, or any other legal theory.

This warranty does not cover any OTC Product that has been abused, altered, worn out, contaminated, rusted, heated, ground, damaged due to side loading, used for a purpose other than that for which it was intended, or used in a manner inconsistent with SPX/OTC's instructions regarding use. The existence of a defect shall be determined by SPX in accordance with procedures established by SPX. No one is authorized to make any statement or representation altering the terms of this warranty.

THIS WARRANTY IS IN LIEU OF ANY OTHER WARRANTY, EXPRESS OR IMPLIED, INCLUDING ANY WARRANTY OF MERCHANTABILITY OR FITNESS FOR A PARTICULAR PURPOSE.

SOFTWARE

The above warranty applies to OTC Product software except that, instead of warranting against defects in materials and workmanship, SPX warrants that OTC Product software, when correctly installed, will execute its programmed instructions. SPX does not warrant that software will operate uninterrupted or error-free. OTC Product software is proprietary, confidential information protected under copyright law. Users have no right in or title to OTC Product software other than a limited right of use revocable by SPX. OTC Product software may not be transferred or disclosed without the written consent of SPX and may not be copied except in ordinary backup procedures.

REPAIR

Should your OTC Product require repair service, return it freight prepaid to an OTC authorized service center, and provide proof of purchase. If the OTC Product is covered by warranty, SPX will return the repaired OTC Product, or a replacement, ground freight prepaid. If the OTC Product is determined to be out of warranty, it will be repaired for a reasonable charge plus return freight.





*SPX Corporation
655 Eisenhower Drive
Owatonna, MN 55060-0995 USA
Phone: (507) 455-7000
Tech. Serv.: (800) 533-6127
Fax: (800) 955-8329
Order Entry: (800) 533-6127
Fax: (800) 283-8665
International Sales: (507) 455-7223
Fax: (507) 455-7063*